

### DIGITAL CALIPERS (STANDARD MODEL)

**INSPECTION CERTIFICATE**  
TRACEABLE TO DKD

- ▶ Resolution: 0.01mm/0.0005"
- ▶ Buttons: on/off, zero, mm/inch
- ▶ Automatic power off, move the digital unit to turn on power
- ▶ Battery CR2032
- ▶ Data output, meet DIN862
- ▶ Made of stainless steel
- ▶ Optional accessory: data output cable

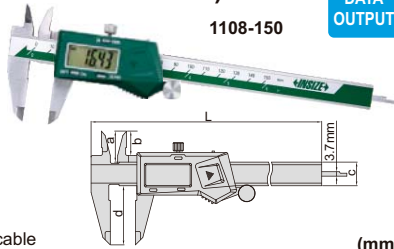

**DATA OUTPUT**

| Code      | Range         | Accuracy | L   | a  | b    | c  | d  | List Price (₹) | Promotion Price (₹) |
|-----------|---------------|----------|-----|----|------|----|----|----------------|---------------------|
| 1108-150* | 0-150mm/0-6"  | ±0.02mm  | 236 | 21 | 16   | 16 | 40 | 2263           | 1757                |
| 1108-200* | 0-200mm/0-8"  | ±0.03mm  | 286 | 24 | 19   | 16 | 50 | 3116           | 2652                |
| 1108-300* | 0-300mm/0-12" | ±0.03mm  | 400 | 25 | 20.5 | 16 | 60 | 5468           | 4761                |

\*Supplied with manufacturer inspection certificate traceable to DKD Germany

### DIGITAL CALIPERS (BASIC MODEL)

**ATTENTION: NO DATE OUTPUT**

- ▶ Resolution: 0.01mm/0.0005"
- ▶ Buttons: zero, on/off, mm/inch
- ▶ Battery LR44
- ▶ Meet DIN862
- ▶ Made of stainless steel

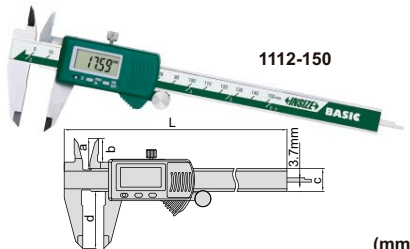

| Code     | Range         | Accuracy | L   | a  | b    | c  | d  | List Price (₹) | Promotion Price (₹) |
|----------|---------------|----------|-----|----|------|----|----|----------------|---------------------|
| 1112-150 | 0-150mm/0-6"  | ±0.03mm  | 236 | 21 | 16   | 16 | 40 | 2010           | 1559                |
| 1112-200 | 0-200mm/0-8"  | ±0.03mm  | 286 | 24 | 19   | 16 | 50 | 2813           | 2366                |
| 1112-300 | 0-300mm/0-12" | ±0.03mm  | 400 | 25 | 20.5 | 17 | 60 | 5188           | 4350                |

### DIGITAL CALIPERS

- ▶ Resolution: 0.01mm/0.0005"
- ▶ Button function: on/off, zero, mm/inch, ABS, data preset
- ▶ Battery CR2032, data output
- ▶ Made of stainless steel
- ▶ Optional accessory: data output cable

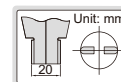
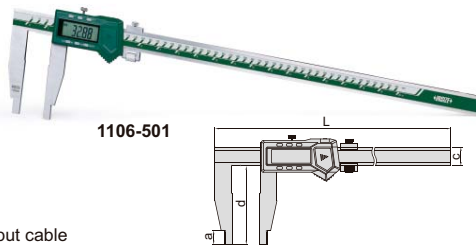

**DATA OUTPUT**

| Code      | Range          | Accuracy | a  | c  | d   | L    | List Price (₹) | Promotion Price (₹) |
|-----------|----------------|----------|----|----|-----|------|----------------|---------------------|
| 1106-501  | 0-500mm/0-20"  | ±0.05mm  | 18 | 24 | 100 | 675  | 12542          | 9886                |
| 1106-601  | 0-600mm/0-24"  | ±0.05mm  | 18 | 24 | 100 | 770  | 16393          | 11630               |
| 1106-1002 | 0-1000mm/0-40" | ±0.08mm  | 24 | 31 | 150 | 1220 | 35886          | 29174               |

### DIGITAL CALIPERS

- ▶ Resolution: 0.01mm/0.0005"
- ▶ Button function: on/off, zero, mm/inch, ABS, data preset
- ▶ Battery CR2032, data output
- ▶ Made of stainless steel
- ▶ Optional accessory: data output cable

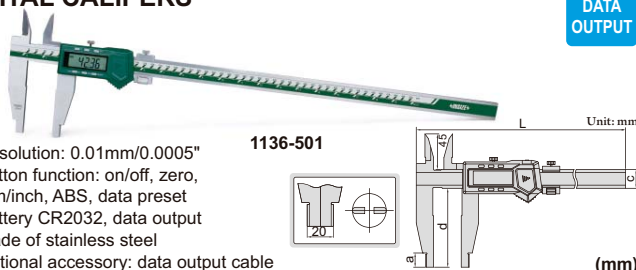

**DATA OUTPUT**

| Code     | Range         | Accuracy | a  | c  | d   | L   | List Price (₹) | Promotion Price (₹) |
|----------|---------------|----------|----|----|-----|-----|----------------|---------------------|
| 1136-501 | 0-500mm/0-20" | ±0.05mm  | 18 | 24 | 100 | 675 | 14754          | 12468               |
| 1136-601 | 0-600mm/0-24" | ±0.05mm  | 18 | 24 | 100 | 770 | 19264          | 14035               |

### DIAL CALIPERS

**INSPECTION CERTIFICATE**  
TRACEABLE TO DKD

**SHOCK PROOF**

- ▶ Accuracy: ±0.03mm
- ▶ Shockproof dial indicator
- ▶ Made of stainless steel

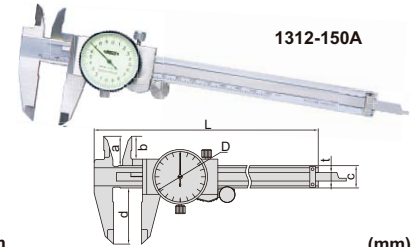

Dial indicator graduation 0.02mm

(mm)

| Code       | Range   | L   | a  | b    | c  | d  | D     | t   | List Price (₹) | Promotion Price (₹) |
|------------|---------|-----|----|------|----|----|-------|-----|----------------|---------------------|
| 1312-150A* | 0-150mm | 235 | 21 | 16.5 | 16 | 40 | Ø39   | 6.5 | 2316           | 2126                |
| 1312-200A* | 0-200mm | 288 | 24 | 19   | 16 | 48 | Ø39   | 6.5 | 3086           | 2832                |
| 1312-300A* | 0-300mm | 410 | 28 | 22   | 20 | 62 | Ø44.5 | 7.5 | 5258           | 4710                |

\*Supplied with manufacturer inspection certificate traceable to DKD Germany

### HEAVY DUTY 300mm DIGITAL CALIPER (PREMIUM MODEL)

**INSPECTION CERTIFICATE**  
TRACEABLE TO DKD

**DATA OUTPUT**

- ▶ Resolution: 0.01mm/0.0005"
- ▶ Buttons: on/off, zero, mm/inch
- ▶ Automatic power off, move the digital unit to turn on power
- ▶ Battery CR2032
- ▶ Data output, meet DIN862
- ▶ Made of stainless steel
- ▶ Optional accessory: data output cable

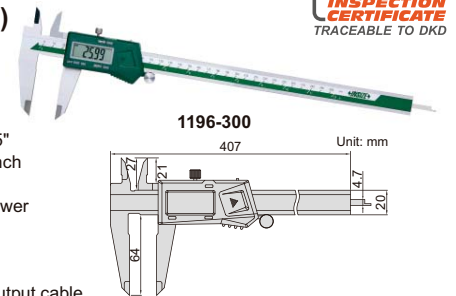

| Code      | Range         | Accuracy | List Price (₹) | Promotion Price (₹) |
|-----------|---------------|----------|----------------|---------------------|
| 1196-300* | 0-300mm/0-12" | ±0.03mm  | 6732           | 6207                |

\*Supplied with manufacturer inspection certificate traceable to DKD Germany

### VERNIER CALIPERS

- ▶ Accuracy: ±0.03mm
- ▶ Graduation: 0.02mm/0.001"
- ▶ Meet DIN862
- ▶ Made of stainless steel
- ▶ Satin chrome plated reading surface

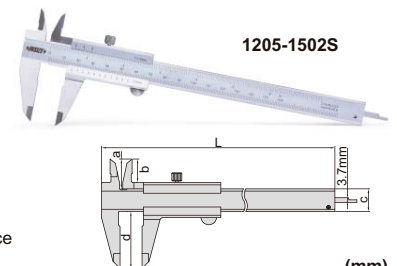

| Code       | Range         | L   | a    | b    | c  | d  | List Price (₹) | Promotion Price (₹) |
|------------|---------------|-----|------|------|----|----|----------------|---------------------|
| 1205-1502S | 0-150mm/0-6"  | 235 | 20.5 | 15.5 | 16 | 40 | 1574           | 1328                |
| 1205-2002S | 0-200mm/0-8"  | 290 | 23.5 | 19   | 17 | 50 | 2373           | 2061                |
| 1205-3002S | 0-300mm/0-12" | 414 | 27.5 | 22   | 20 | 64 | 4398           | 3792                |

## VERNIER CALIPERS

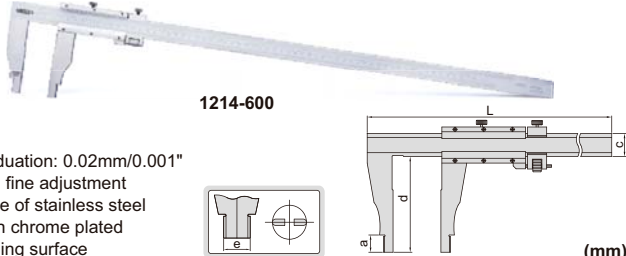

**1214-600**

- ▶ Graduation: 0.02mm/0.001"
- ▶ With fine adjustment
- ▶ Made of stainless steel
- ▶ Satin chrome plated reading surface

| Code      | Range          | Accuracy | a  | c  | d   | e  | L    | List Price (₹) | Promotion Price (₹) |
|-----------|----------------|----------|----|----|-----|----|------|----------------|---------------------|
| 1214-500  | 0-500mm/0-20"  | ±0.05mm  | 18 | 24 | 100 | 20 | 670  | 7838           | 6584                |
| 1214-600  | 0-600mm/0-24"  | ±0.05mm  | 18 | 24 | 100 | 20 | 770  | 8847           | 7342                |
| 1214-1000 | 0-1000mm/0-40" | ±0.08mm  | 24 | 32 | 140 | 20 | 1216 | 25414          | 21744               |

## ACCESSORY SET FOR DIGITAL CALIPERS CODE 6144

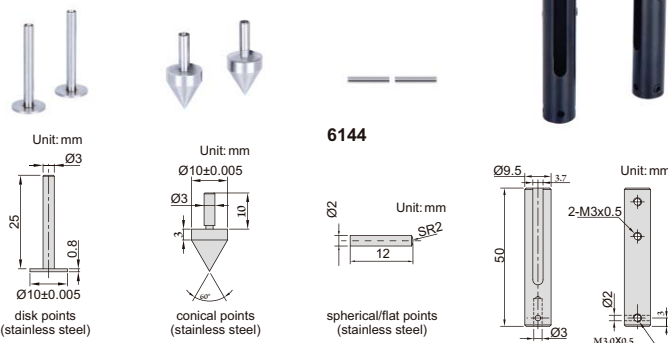

**6144**

- ▶ Suitable for 0-150mm/0-6" and 0-200mm/0-8" digital calipers (thickness of lower jaws ≤ 3.7mm)

| Code | List Price (₹) | Promotion Price (₹) |
|------|----------------|---------------------|
| 6144 | 2917           | 2536                |

## DEPTH BASE ATTACHMENT



**6140**

- ▶ To increase the stability of depth measurement
- ▶ Suitable for digital calipers and dial calipers
- ▶ Made of stainless steel

| Code | Application                                    | List Price (₹) | Promotion Price (₹) |
|------|--|----------------|---------------------|
| 6140 | Suitable for calipers with beam width (w) 16mm | 750            | 642                 |

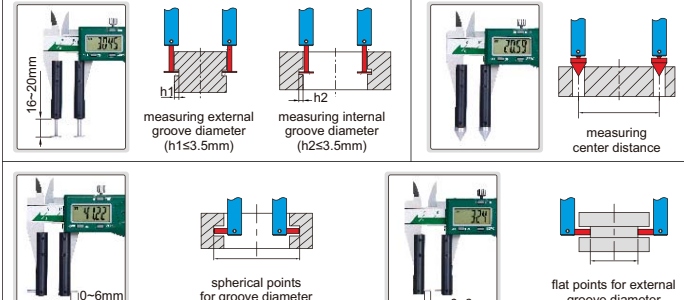

- ▶ measuring external groove diameter (h1 ≤ 3.5mm)
- ▶ measuring internal groove diameter (h2 ≤ 3.5mm)
- ▶ measuring center distance
- ▶ spherical points for groove diameter (inside hole) measurement
- ▶ flat points for external groove diameter measurement

## DIGITAL CALIPER WITH INTERCHANGEABLE POINTS CODE 1526-200

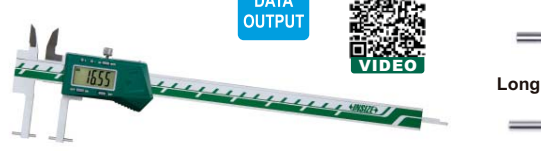

**1526-200**

- ▶ Supplied with 3 pairs of points and zero setting block for external measurement
- ▶ Resolution: 0.01mm/0.0005"
- ▶ Buttons: on/off, set, mm/inch, preset (+, -)
- ▶ Automatic power off, move the digital unit to turn on power
- ▶ Battery CR2032, data output
- ▶ Made of stainless steel
- ▶ Optional accessory: points (code 1526-T101, 7392, 7391, 7381, 7321), depth stop (code 6143), data output cable

| Code     | List Price (₹) | Promotion Price (₹) |
|----------|----------------|---------------------|
| 1526-200 | 14412          | 11552               |

| Point                      | Range   | Accuracy | Application  |
|----------------------------|---|----------|--|
| short spherical points     | 12-212mm/0.5-8.5"(internal)                           | ±0.03mm  | for grooves inside small hole  |
| long spherical/flat points | 24-224mm/1-8.8"(internal)<br>0-187mm/0-7.5"(external) | ±0.03mm  | spherical points for grooves inside hole<br>flat points for external grooves |
| spherical blade points     | 24-224mm/1-8.8"(internal)<br>0-187mm/0-7.5"(external) | ±0.03mm  | for narrow grooves inside hole   |

## DIGITAL INSIDE GROOVE CALIPER



**1176-150**

- ▶ Measure diameter of grooves inside bores
- ▶ Resolution: 0.01mm/0.0005"
- ▶ Buttons: on/off, set, mm/inch, preset (+, -)
- ▶ Automatic power off, move the digital unit to turn on power
- ▶ Battery CR2032, data output
- ▶ Made of stainless steel
- ▶ Optional accessory: depth stop (code 6143), data output cable

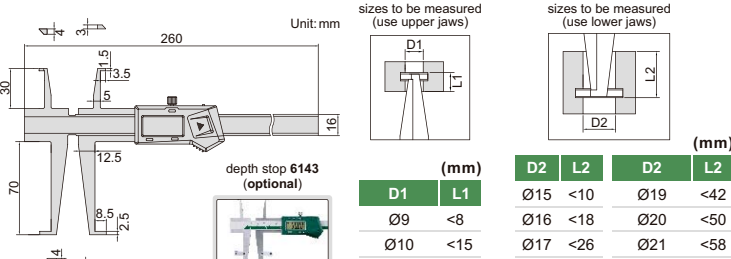

Unit: mm

depth stop 6143 (optional)

| sizes to be measured (use upper jaws) |     | sizes to be measured (use lower jaws) |     |
|---------------------------------------|-----|---------------------------------------|-----|
| D1                                    | L1  | D2                                    | L2  |
| Ø9                                    | <8  | Ø15                                   | <10 |
| Ø10                                   | <15 | Ø16                                   | <18 |
| Ø11~150                               | <30 | Ø17                                   | <26 |
|                                       |     | Ø18                                   | <34 |
|                                       |     | Ø20                                   | <50 |
|                                       |     | Ø21                                   | <58 |
|                                       |     | Ø22~150                               | <70 |

| Code     | Range of upper jaw | Range of lower jaw | Accuracy | List Price (₹) | Promotion Price (₹) |
|----------|--------------------|--------------------|----------|----------------|---------------------|
| 1176-150 | 9-150mm/0.35-6"    | 15-150mm/0.59-6"   | ±0.04mm  | 10871          | 9772                |

DIGITAL INSIDE GROOVE CALIPER

DATA OUTPUT



1120-150A



- ▶ Measure groove diameter
- ▶ Resolution: 0.01mm/0.0005"
- ▶ Buttons: on/off, set, mm/inch, preset (+, -)
- ▶ Automatic power off, move the digital unit to turn on power
- ▶ Battery CR2032, data output
- ▶ Made of stainless steel
- ▶ Optional accessory: depth stop (code 6143), data output cable

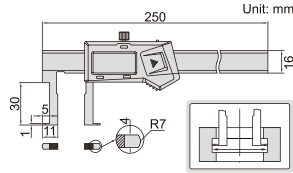

| Code      | Range    | Accuracy | List Price (₹) | Promotion Price (₹) |
|-----------|----------|----------|----------------|---------------------|
| 1120-150A | 22-150mm | ±0.04mm  | 7589           | 5247                |

DIGITAL DEPTH GAGES (STANDARD MODEL)

DATA OUTPUT



1141-150A

- ▶ Resolution: 0.01mm/0.0005"
- ▶ Buttons: on/off, zero, mm/inch
- ▶ Automatic power off, move the digital unit to turn on power
- ▶ Meet DIN862
- ▶ Battery CR2032, data output
- ▶ Made of stainless steel
- ▶ Optional accessory: data output cable

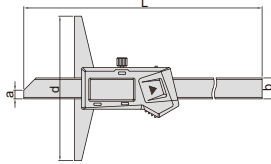

| Code      | Range         | Accuracy | L   | a | b    | d   | List Price (₹) | Promotion Price (₹) |
|-----------|---------------|----------|-----|---|------|-----|----------------|---------------------|
| 1141-150A | 0-150mm/0-6"  | ±0.03mm  | 230 | 6 | 14.5 | 100 | 3289           | 2533                |
| 1141-200A | 0-200mm/0-8"  | ±0.03mm  | 280 | 6 | 14.5 | 100 | 3993           | 3076                |
| 1141-300A | 0-300mm/0-12" | ±0.03mm  | 380 | 6 | 14.5 | 150 | 8488           | 6545                |

WATERPROOF DIGITAL DEPTH GAGES

IP67 WATERPROOF

ATTENTION: IT IS NECESSARY TO SET ZERO AFTER POWER ON EACH TIME

ATTENTION: NO DATE OUTPUT



1149-150

- ▶ IP67 dust/waterproof
- ▶ Resolution: 0.01mm/0.0005"
- ▶ Button function: zero, on/off, mm/inch, ABS/REL, hold
- ▶ Meet DIN862
- ▶ Battery CR2032
- ▶ Made of stainless steel

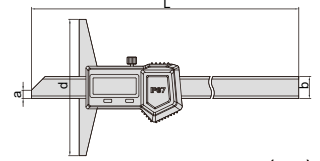

| Code     | Range         | Accuracy | L   | a | b  | d   | List Price (₹) | Promotion Price (₹) |
|----------|---------------|----------|-----|---|----|-----|----------------|---------------------|
| 1149-150 | 0-150mm/0-6"  | ±0.03mm  | 240 | 6 | 16 | 100 | 10506          | 8328                |
| 1149-200 | 0-200mm/0-8"  | ±0.03mm  | 290 | 6 | 16 | 100 | 14376          | 11396               |
| 1149-300 | 0-300mm/0-12" | ±0.03mm  | 390 | 6 | 16 | 150 | 18447          | 14623               |

VERNIER DEPTH GAGES (STANDARD MODEL)



1240-2001

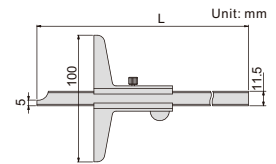

- ▶ Made of stainless steel
- ▶ Satin chrome plated reading surface

| Code      | Range   | Graduation | Accuracy | L   | List Price (₹) | Promotion Price (₹) |
|-----------|---------|------------|----------|-----|----------------|---------------------|
| 1240-1501 | 0-150mm | 0.02mm     | ±0.03mm  | 245 | 1877           | 1423                |
| 1240-2001 | 0-200mm | 0.02mm     | ±0.03mm  | 282 | 1942           | 1576                |
| 1240-3001 | 0-300mm | 0.02mm     | ±0.04mm  | 382 | 2516           | 2136                |

DIGITAL DEPTH GAGES WITH ROUND DEPTH BAR

- ▶ Resolution: 0.01mm/0.0005"
- ▶ Supplied with three interchangeable points (flat, spherical, disk)
- ▶ Buttons: on/off, set, mm/inch, preset (+, -)
- ▶ Automatic power off, move the digital unit to turn on power
- ▶ Battery CR2032, data output
- ▶ Made of stainless steel
- ▶ Optional accessory: data output cable, disk points (see below table), extension base (code 6141)

MEASURE WIDTH AND DEPTH OF GROOVES INSIDE BORE

MEASURE DEPTH OF SMALL HOLES (>Ø4mm)

DATA OUTPUT



1148-200

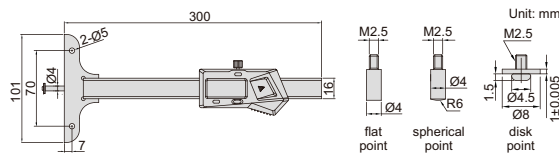
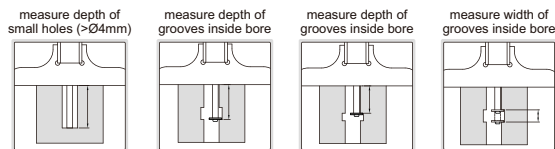

1148-P103 (optional), measure width of bottom grooves inside blind hole

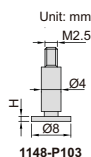
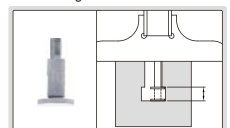

1148-P103

| Code     | Range        | Accuracy | Remark                                 | List Price (₹) | Promotion Price (₹) |
|----------|--------------|----------|--|----------------|---------------------|
| 1148-200 | 0-200mm/0-8" | ±0.03mm  | with mounting holes for extension base | 13966          | 12466               |

\*When disk points are used, the range is reduced by 10mm

OPTIONAL DISK POINT

| Code      | Description    | H         | Remark                        | List Price (₹) | Promotion Price (₹) |
|-----------|----------------|-----------|-------------------------------|----------------|---------------------|
| 1148-P103 | 1mm disk point | 1±0.005mm | for grooves inside blind hole | 1137           | 1000                |

## DIGITAL DEPTH GAGE

DATA OUTPUT



2141-202A

- ▶ Digital indicator stroke: 12.7mm/0.5"
- ▶ Digital indicator resolution: 0.01mm/0.0005"
- ▶ Button function: on/off, zero, mm/inch, ABS, data preset, change measuring direction
- ▶ CR2032 battery, automatic power off
- ▶ Data output
- ▶ Stainless steel base
- ▶ Extension rods: 12.5mm (1 pc), 25mm (1 pc), 50mm (1 pc), 75mm (1 pc), 100mm (2 pcs)
- ▶ Supplied with pointed tip and ball tip
- ▶ Optional accessory: data output cable



VIDEO

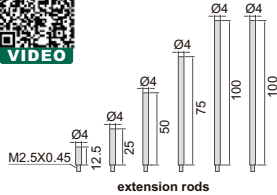
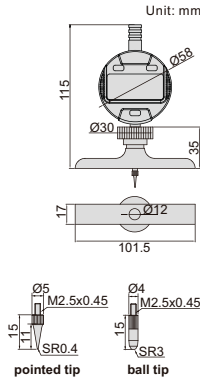

| Code      | Range         | Accuracy | Base       | List Price (₹) | Promotion Price (₹) |
|-----------|---------------|----------|------------|----------------|---------------------|
| 2141-202A | 0-300mm/0-12" | ±20µm    | 101.5x17mm | 9638           | 6971                |

## DIAL DEPTH GAGE



VIDEO



2342-202

- ▶ Dial indicator stroke: 30mm
- ▶ Dial indicator graduation: 0.01mm
- ▶ Stainless steel base
- ▶ Extension rods: 25mm (1 pc), 50mm (1 pc), 75mm (1 pc), 100mm (2 pcs)
- ▶ Supplied with pointed tip and ball tip

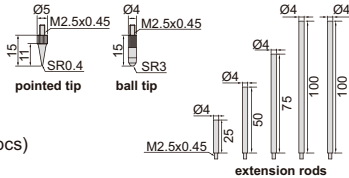

| Code     | Range   | Base       | Accuracy | List Price (₹) | Promotion Price (₹) |
|----------|---------|------------|----------|----------------|---------------------|
| 2342-202 | 0-300mm | 101.5x17mm | ±0.03mm  | 7184           | 6369                |

## DEPTH MICROMETER

- ▶ Graduation: 0.01mm
- ▶ Meet DIN863-2
- ▶ Micrometer head accuracy: +/3µm
- ▶ Rod accuracy: +/-(2+L/75)µm, L is the measuring range in mm
- ▶ Rods with flat end
- ▶ Ratchet stop



3240-25

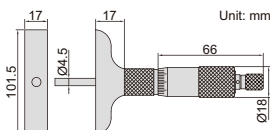
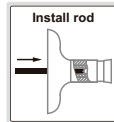

| Code    | Range  | Rods | List Price (₹) | Promotion Price (₹) |
|---------|--------|------|----------------|---------------------|
| 3240-25 | 0-25mm | 1 pc | 2984           | 2580                |

## DIAL DEPTH GAGE

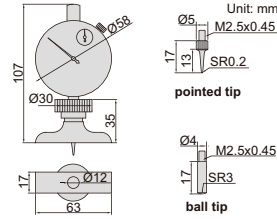

Unit: mm  
M2.5x0.45  
SR0.2

pointed tip

M2.5x0.45  
SR3

ball tip



2341-101A

- ▶ Dial indicator graduation: 0.01mm
- ▶ Stainless steel base
- ▶ Supplied with pointed tip and ball tip

| Code      | Range  | Dial indicator stroke | Accuracy | List Price (₹) | Promotion Price (₹) |
|-----------|--------|-----------------------|----------|----------------|---------------------|
| 2341-101A | 0-10mm | 10mm                  | ±0.017mm | 4193           | 3454                |

## DEPTH MICROMETERS

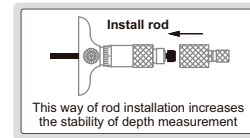

This way of rod installation increases the stability of depth measurement



3241-150

- ▶ Graduation: 0.01mm, meet DIN863-2
- ▶ Micrometer head accuracy: +/3µm
- ▶ Rod accuracy: +/-(2+L/75)µm, L is the measuring range in mm
- ▶ Rods with flat end
- ▶ Ratchet stop

| Code     | Range   | Rods   | List Price (₹) | Promotion Price (₹) |
|----------|---------|--------|----------------|---------------------|
| 3241-150 | 0-150mm | 6 pcs  | 7615           | 6880                |
| 3241-300 | 0-300mm | 12 pcs | 12150          | 11246               |

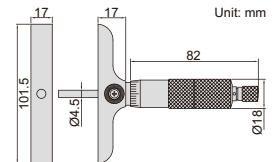

## DIGITAL HEIGHT GAGE (ECONOMIC MODEL)

ATTENTION: LOW ACCURACY

DATA OUTPUT

ATTENTION: CAN NOT USE CLAMP FOR PROTRACTORS (CODE 2372-CLAMP)

dial test indicator holder (included)

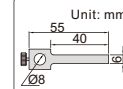
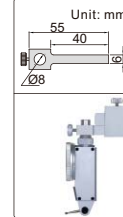

1150-300

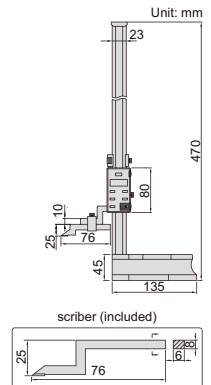

scraper (included)

dust cover (included)



- ▶ Resolution: 0.01mm/0.0005"
- ▶ Buttons: on/off, zero, mm/inch, ABS/INC, data hold, TOL, set
- ▶ ABS/INC is for absolute and incremental measurement
- ▶ TOL is for tolerance measurement
- ▶ Carbide tipped scriber
- ▶ Made of stainless steel (except the base)
- ▶ LR44 battery, data output
- ▶ Supplied with dial test indicator holder
- ▶ Supplied with dust cover
- ▶ Optional accessory: data output cable (code 7301-SPC5)

| Code     | Range         | Accuracy | List Price (₹) | Promotion Price (₹) |
|----------|---------------|----------|----------------|---------------------|
| 1150-300 | 0-300mm/0-12" | ±0.05mm  | 17399          | 11634               |

DIGITAL HEIGHT GAGES WITH DRIVING WHEEL

**1156-300**

**1156-1000**

**DATA OUTPUT**

Resolution: 0.01mm/0.0005"  
 Buttons: on/off, zero, mm/inch, preset (+, -), hold  
 Automatic power off, move the digital unit to turn on power  
 Carbide tipped scriber  
 Made of stainless steel  
 Battery CR2032, data output  
 Supplied with dust cover  
 Optional accessory: data output cable, dial test indicator holder (code 6293-6), clamp for protractors (code 2372-CLAMP)

**INSPECTION CERTIFICATE TRACEABLE TO DKD**

clamp for protractors (optional)  
 Unit: mm  
 2.6  
 9.5  
**2372-CLAMP**

dial test indicator holder (optional)  
 Unit: mm  
**6293-6**

| Code       | Range          | Accuracy | L    | W   | H  | a  | b  | c  | h  | List Price (₹) | Promotion Price (₹) |
|------------|----------------|----------|------|-----|----|----|----|----|----|----------------|---------------------|
| 1156-300*  | 0-300mm/0-12"  | ±0.03mm  | 515  | 180 | 55 | 80 | 30 | 35 | 9  | 20139          | 17553               |
| 1156-600*  | 0-600mm/0-24"  | ±0.05mm  | 815  | 180 | 55 | 80 | 30 | 35 | 9  | 30261          | 27422               |
| 1156-1000* | 0-1000mm/0-40" | ±0.07mm  | 1220 | 265 | 70 | 92 | 48 | 40 | 12 | 116811         | 108858              |

(mm)

\*Supplied with manufacturer inspection certificate traceable to DKD Germany

VERNIER HEIGHT GAGES

**6293-6**

**1250-300**

**2372-CLAMP**

Graduation: 0.02mm/0.001"  
 Adjustable main scale to set zero  
 Carbide tipped scriber  
 Made of stainless steel (except the base)  
 Satin chrome plated scale  
 Supplied with magnifier  
 With fine adjustment  
 Supplied with dust cover  
 Optional accessory: dial test indicator holder (code 6293-6), clamp for protractors (code 2372-CLAMP)

dial test indicator holder (optional)  
 Unit: mm  
**6293-6**

clamp for protractors (optional)  
 Unit: mm  
 2.6  
 9.5  
**2372-CLAMP**

dust cover (included)

| Code     | Range         | Accuracy | L   | a1  | a2 | b  | c1 | c2 | d  | List Price (₹) | Promotion Price (₹) |
|----------|---------------|----------|-----|-----|----|----|----|----|----|----------------|---------------------|
| 1250-300 | 0-300mm/0-12" | ±0.04mm  | 545 | 135 | 43 | 75 | 80 | 30 | 28 | 10270          | 8864                |
| 1250-600 | 0-600mm/0-24" | ±0.05mm  | 870 | 180 | 54 | 85 | 80 | 41 | 35 | 15761          | 14204               |

(mm)

DIGITAL HEIGHT GAGE (LIGHT DUTY)

**1154-150**

**DATA OUTPUT**

Accuracy: ±0.03mm  
 Buttons: on/off, zero, mm/inch  
 Automatic power off, move the digital unit to turn on power  
 Carbide tipped scriber  
 With fine adjustment  
 Made of stainless steel  
 Battery CR2032, data output  
 Optional accessory: data output cable, dial test indicator holder (code 7151-CL1)

**ATTENTION: CAN NOT USE CLAMP FOR PROTRACTORS (CODE 2372-CLAMP)**

dial test indicator holder (optional)  
 Unit: mm  
**7151-CL1**

| Code     | Range        | Resolution     | List Price (₹) | Promotion Price (₹) |
|----------|--------------|----------------|----------------|---------------------|
| 1154-150 | 0-150mm/0-6" | 0.01mm/0.0005" | 7543           | 5502                |

VERNIER HEIGHT GAGE (LIGHT DUTY)

**7151-CL1**

**1253-200**

Graduation 0.02mm/0.001"  
 Carbide tipped scriber  
 Made of stainless steel (except the base)  
 Satin chrome plated scale  
 Optional accessory: dial test indicator holder (code 7151-CL1)

**ATTENTION: CAN NOT USE CLAMP FOR PROTRACTORS (CODE 2372-CLAMP)**

dial test indicator holder (optional)  
 Unit: mm  
**7151-CL1**

| Code     | Range        | Accuracy | List Price (₹) | Promotion Price (₹) |
|----------|--------------|----------|----------------|---------------------|
| 1253-200 | 0-200mm/0-8" | ±0.03mm  | 8909           | 6918                |

DIGITAL OUTSIDE MICROMETERS

**3109-25A**

**3109-50A**

Resolution 0.001mm/0.00005"  
 Button function: on/off, set, mm/inch, ABS/INC  
 No data output  
 LR44 battery, automatic power off  
 Carbide measuring faces  
 Friction thimble  
 Supplied with spherical anvil  
 Setting standards are included (except 0-25mm/0-1")

**ATTENTION: NO DATE OUTPUT**

**INSPECTION CERTIFICATE TRACEABLE TO DKD**

spherical anvil is included

friction thimble for one hand operation

measure tube wall thickness

| Code      | Range        | Accuracy | L  | a | b    | List Price (₹) | Promotion Price (₹) |
|-----------|--------------|----------|----|---|------|----------------|---------------------|
| 3109-25A* | 0-25mm/0-1"  | ±2µm     | 32 | 6 | 27.5 | 3905           | 3177                |
| 3109-50A* | 25-50mm/1-2" | ±2µm     | 57 | 8 | 37   | 4715           | 4223                |

(mm)

\*Supplied with manufacturer inspection certificate traceable to DKD Germany

## DIGITAL OUTSIDE MICROMETERS (WITHOUT DATA OUTPUT)



3108-25A

without data output



ATTENTION: NO DATA OUTPUT

IP65 WATERPROOF

spherical anvil is included

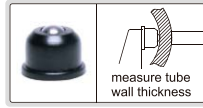

- ▶ Resolution 0.001mm/0.00005"
- ▶ IP65 dust/waterproof
- ▶ Button function: on/off, set, mm/inch, ABS/INC
- ▶ No data output
- ▶ LR44 battery, automatic power off
- ▶ Carbide measuring faces
- ▶ Ratchet stop
- ▶ Supplied with spherical anvil
- ▶ Setting standards are included (except 0-25mm/0-1")

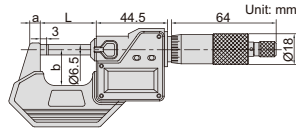

(mm)

| Code      | Range        | Accuracy | L    | a | b  | List Price (₹) | Promotion Price (₹) |
|-----------|--------------|----------|------|---|----|----------------|---------------------|
| 3108-25A* | 0-25mm/0-1"  | ±2µm     | 34.5 | 6 | 25 | 5257           | 4864                |
| 3108-50A* | 25-50mm/1-2" | ±2µm     | 59.5 | 8 | 32 | 6569           | 5909                |

\*Supplied with manufacturer inspection certificate traceable to DKD Germany

## DIGITAL OUTSIDE MICROMETERS (WITH DATA OUTPUT)



3101-25A

data output



spherical anvil is included



- ▶ Resolution 0.001mm/0.00005"
- ▶ IP65 dust/waterproof
- ▶ Button function: on/off, set, mm/inch, ABS/INC
- ▶ Data output
- ▶ LR44 battery, automatic power off
- ▶ Carbide measuring faces
- ▶ Ratchet stop
- ▶ Supplied with spherical anvil
- ▶ Setting standards are included (except 0-25mm/0-1")
- ▶ Optional accessory: data output cable

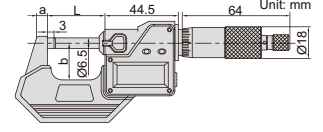

(mm)

| Code      | Range        | Accuracy | L    | a | b  | List Price (₹) | Promotion Price (₹) |
|-----------|--------------|----------|------|---|----|----------------|---------------------|
| 3101-25A* | 0-25mm/0-1"  | ±2µm     | 34.5 | 6 | 25 | 9570           | 7886                |
| 3101-50A* | 25-50mm/1-2" | ±2µm     | 59.5 | 8 | 32 | 10319          | 8534                |

\*Supplied with manufacturer inspection certificate traceable to DKD Germany

## 1µm GRADUATION OUTSIDE MICROMETERS



3210-25A

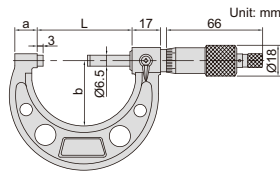

- ▶ Graduation: 0.001mm
- ▶ Carbide measuring faces
- ▶ Meet DIN863-1, ratchet stop
- ▶ Supplied with setting standards (except 0-25mm)

(mm)

| Code      | Range   | Accuracy | L  | a  | b  | List Price (₹) | Promotion Price (₹) |
|-----------|---------|----------|----|----|----|----------------|---------------------|
| 3210-25A* | 0-25mm  | 4µm      | 32 | 9  | 28 | 1640           | 1449                |
| 3210-50A* | 25-50mm | 4µm      | 57 | 14 | 38 | 1799           | 1598                |

\*Supplied with manufacturer inspection certificate traceable to DKD Germany

## OUTSIDE MICROMETERS



- ▶ Graduation: 0.01mm
- ▶ Carbide measuring faces, ratchet stop
- ▶ Meet DIN863-1
- ▶ Supplied with setting standards (except 0-25mm)



3203-50A

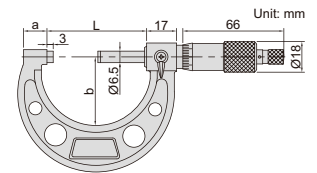

| Code       | Range    | Accuracy | L   | a  | b  | List Price (₹) | Promotion Price (₹) |
|------------|----------|----------|-----|----|----|----------------|---------------------|
| 3203-25A*  | 0-25mm   | ±2µm     | 32  | 9  | 28 | 1385           | 1205                |
| 3203-50A*  | 25-50mm  | ±2µm     | 57  | 14 | 38 | 1570           | 1424                |
| 3203-75A*  | 50-75mm  | ±2µm     | 82  | 15 | 49 | 1821           | 1593                |
| 3203-100A* | 75-100mm | ±3µm     | 107 | 15 | 60 | 2025           | 1766                |

Set

| Code        | Range   | Micrometers included                    | Packaging       | List Price (₹) | Promotion Price (₹) |
|-------------|---------|---|-----------------|----------------|---------------------|
| 3203-1004A* | 0-100mm | 3203-25A, 3203-50A, 3203-75A, 3203-100A | blow mould case | 6369           | 6024                |

\*Supplied with manufacturer inspection certificate traceable to DKD Germany

## SPHERICAL ANVIL TUBE MICROMETER

- ▶ Meet DIN863-3
- ▶ Measure wall thickness of tubes
- ▶ Graduation 0.01mm
- ▶ Ratchet stop
- ▶ Carbide measuring faces



3260-25SA

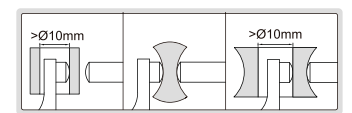
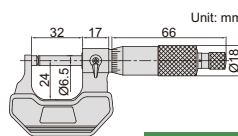

| Code      | Range  | Accuracy | List Price (₹) | Promotion Price (₹) |
|-----------|--------|----------|----------------|---------------------|
| 3260-25SA | 0-25mm | 4µm      | 2251           | 1909                |

OUTSIDE MICROMETERS WITH INTERCHANGEABLE ANVILS

- ▶ Graduation: 0.01mm
- ▶ Ratchet stop
- ▶ Meet DIN863-3
- ▶ Carbide measuring faces
- ▶ Supplied with setting standards



3206-150A

setting standards are included

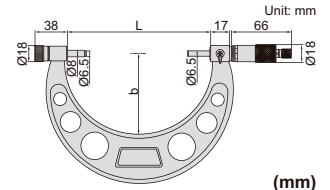
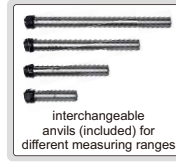

(mm)

| Code      | Range     | Accuracy | L   | b   | Setting standard (included)  | List Price (₹) | Promotion Price (₹) |
|-----------|-----------|----------|-----|-----|------------------------------|----------------|---------------------|
| 3206-150A | 0-150mm   | 6µm      | 158 | 82  | 25, 50, 75, 100, 125         | 10733          | 9525                |
| 3206-300A | 150-300mm | 9µm      | 308 | 165 | 150, 175, 200, 225, 250, 275 | 13733          | 11541               |

MICROMETER STAND



6301

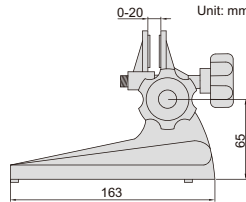

Unit: mm

- ▶ Suitable for micrometers up to 100mm

| Code | List Price (₹) | Promotion Price (₹) |
|------|----------------|---------------------|
| 6301 | 1029           | 738                 |

MICROMETER HEAD

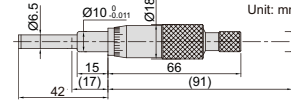

Unit: mm

- ▶ Meet DIN863-2
- ▶ Graduation 0.01mm
- ▶ Ratchet stop



6381-25W

| Code     | Range  | Stem  | Spindle tip    | Accuracy | List Price (₹) | Promotion Price (₹) |
|----------|--------|-------|----------------|----------|----------------|---------------------|
| 6381-25W | 0-25mm | plain | flat (carbide) | 3µm      | 1423           | 1023                |

THREE POINTS INTERNAL MICROMETERS

- ▶ Meet DIN863-4
- ▶ 6-12mm: graduation 0.001mm, 12-100mm: graduation 0.005mm
- ▶ Ratchet stop
- ▶ Optional accessory: setting rings (code 6312), micrometer stand and clamp (code 6301 and 6301-2)



Individual

| Code      | Range    | Type | Accuracy | Setting ring (included) | Extension rod (included) | L    | a   | b    | c    | List Price (₹) | Promotion Price (₹) |
|-----------|----------|------|----------|-------------------------|--------------------------|------|-----|------|------|----------------|---------------------|
| 3227-8*   | 6-8mm    | A    | 4µm      | Ø6mm                    | 100mm                    | 54.5 | 1.5 | 2.5  | —    | 15878          | 13696               |
| 3227-10*  | 8-10mm   | A    | 4µm      | Ø8mm                    | 100mm                    | 54.5 | 1.5 | 2.5  | —    | 15878          | 13696               |
| 3227-12*  | 10-12mm  | A    | 4µm      | Ø10mm                   | 100mm                    | 54.5 | 1.5 | 2.5  | —    | 15878          | 13696               |
| 3227-16*  | 12-16mm  | B    | 4µm      | Ø16mm                   | 150mm                    | 80   | 0.5 | 6    | 4.5  | 11996          | 10346               |
| 3227-20*  | 16-20mm  | B    | 4µm      | Ø16mm                   | 150mm                    | 80   | 0.5 | 6    | 4.5  | 11996          | 10346               |
| 3227-25*  | 20-25mm  | B    | 4µm      | Ø25mm                   | 150mm                    | 90   | 0.5 | 8    | 6    | 16861          | 14543               |
| 3227-30*  | 25-30mm  | B    | 4µm      | Ø25mm                   | 150mm                    | 90   | 0.5 | 8    | 6    | 16861          | 14543               |
| 3227-40*  | 30-40mm  | B    | 4µm      | Ø40mm                   | 150mm                    | 97   | 0.5 | 14   | 12   | 18160          | 15664               |
| 3227-50*  | 40-50mm  | B    | 5µm      | Ø40mm                   | 150mm                    | 97   | 0.5 | 14   | 12   | 21090          | 18191               |
| 3227-63*  | 50-63mm  | C    | 5µm      | Ø62mm                   | 150mm                    | 114  | 0.5 | 17.5 | 14.5 | 22832          | 19694               |
| 3227-75*  | 62-75mm  | C    | 5µm      | Ø62mm                   | 150mm                    | 114  | 0.5 | 17.5 | 14.5 | 24491          | 21125               |
| 3227-88*  | 75-88mm  | C    | 5µm      | Ø87mm                   | 150mm                    | 114  | 0.5 | 17.5 | 14.5 | 25598          | 22079               |
| 3227-100* | 87-100mm | C    | 5µm      | Ø87mm                   | 150mm                    | 114  | 0.5 | 17.5 | 14.5 | 26621          | 22961               |

(mm)

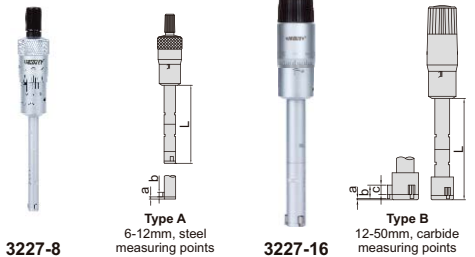

3227-8

Type A 6-12mm, steel measuring points

3227-16

Type B 12-50mm, carbide measuring points

Set

| Code       | Range    | Micrometers Included                | Setting ring (included) | Extension rod (included) | List Price (₹) | Promotion Price (₹) |
|------------|----------|-------------------------------------|-------------------------|--------------------------|----------------|---------------------|
| 3227-123*  | 6-12mm   | 6-8mm, 8-10mm, 10-12mm              | Ø6mm, Ø8mm, Ø10mm       | 100mm                    | 44423          | 38316               |
| 3227-202*  | 12-20mm  | 12-16mm, 16-20mm                    | Ø16mm                   | 150mm                    | 22327          | 19258               |
| 3227-504*  | 20-50mm  | 20-25mm, 25-30mm, 30-40mm, 40-50mm  | Ø25mm, Ø40mm            | 150mm                    | 63746          | 54983               |
| 3227-1004* | 50-100mm | 50-63mm, 62-75mm, 75-88mm, 87-100mm | Ø62mm, Ø87mm            | 150mm                    | 85282          | 73558               |

\*Supplied with manufacturer inspection certificate



micrometer stand with clamp (optional)



3227-504



3227-100

setting rings are included

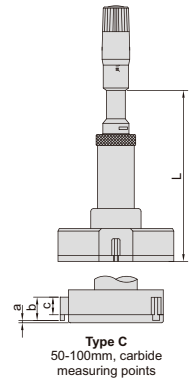

Type C 50-100mm, carbide measuring points

extension rods are included



INSIDE MICROMETER

- ▶ Graduation 0.01mm
- ▶ Ratchet stop
- ▶ Carbide measuring faces
- ▶ Optional accessory: setting ring (code 6312), micrometer stand and clamp (code 6301 and 6301-1)



3220-30

| Code    | Range  | Setting ring   | Accuracy | List Price (₹) | Promotion Price (₹) |
|---------|--------|----------------|----------|----------------|---------------------|
| 3220-30 | 5-30mm | 5mm (included) | 7µm      | 4120           | 3517                |

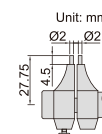

Unit: mm

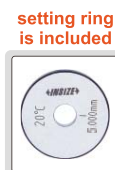

setting ring is included



micrometer stand with clamp (optional)

## DIGITAL INSIDE MICROMETER

- ▶ Resolution: 0.001mm/0.00005"
- ▶ Button function: on/off, set, mm/inch, ABS/INC, data output
- ▶ Data output
- ▶ LR44 battery, automatic power off
- ▶ Ratchet stop
- ▶ Carbide measuring faces
- ▶ Optional accessory: data output cable, setting ring (code 6312)



| Code    | Range             | Setting ring   | Accuracy | List Price (₹) | Promotion Price (₹) |
|---------|-------------------|----------------|----------|----------------|---------------------|
| 3520-30 | 5-30mm / 0.2-1.2" | 5mm (included) | ±5µm     | 14662          | 11619               |

## TUBULAR INSIDE MICROMETER

- ▶ Range: 50-300mm, graduation: 0.01mm
- ▶ Extension rods 13mm, 25mm, 50mm (2 pcs), 100mm
- ▶ Accuracy: (3+n+L/50)µm  
 n=number of rods  
 L=maximum measuring length (mm)
- ▶ Supplied with setting standards, carbide measuring faces



| Code     | Travel of micrometer head | List Price (₹) | Promotion Price (₹) |
|----------|---------------------------|----------------|---------------------|
| 3222-300 | 13mm                      | 8372           | 7701                |

## BORE GAGES FOR SMALL HOLES

ATTENTION: NOT SUITABLE FOR 0.001MM DIAL INDICATORS



- ▶ Accuracy: ±0.012mm
- ▶ Repeatability: 0.003mm
- ▶ Optional accessory: setting ring (code 6312)

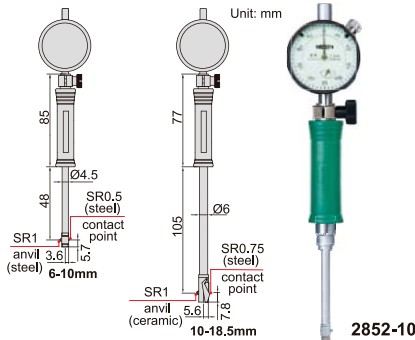

With dial indicator

| Code    | Range     | Indicator   | List Price (₹) | Promotion Price (₹) |
|---------|-----------|---|----------------|---------------------|
| 2852-10 | 6-10mm    | dial indicator, range 3mm, graduation 0.01mm (code 2311-3F) | 8787           | 6437                |
| 2852-18 | 10-18.5mm |   | 7926           | 6307                |

## BORE GAGE SETTER

gage blocks are included

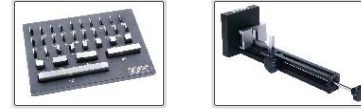

- ▶ Vertical and horizontal use
- ▶ To be used with gage blocks
- ▶ With gage block set

Gage block set for 7353-160

| Blocks per set | Size (mm) | Step (mm) | Quantity (pcs) | Remark            |
|----------------|-----------|-----------|----------------|-------------------|
| 33             | 1.005     |           | 1              | grade 2 (ISO3650) |
|                | 1.01-1.09 | 0.01      | 9              |                   |
|                | 1.1-1.9   | 0.1       | 9              |                   |
|                | 1-9       | 1         | 9              |                   |
|                | 10-30     | 10        | 3              |                   |
|                | 50        |           | 1              |                   |
|                | 100       |           | 1              |                   |

| Code     | Range   | Repeatability | List Price (₹) | Promotion Price (₹) |
|----------|---------|---------------|----------------|---------------------|
| 7353-160 | 0-160mm | 1.2µm         | 25690          | 22461               |

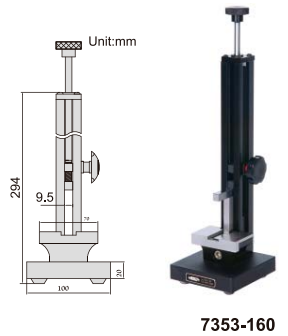

## BORE GAGES

ATTENTION: NOT SUITABLE FOR 0.001MM DIAL INDICATORS

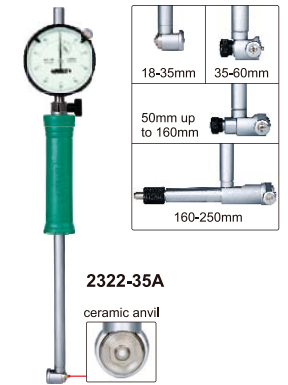
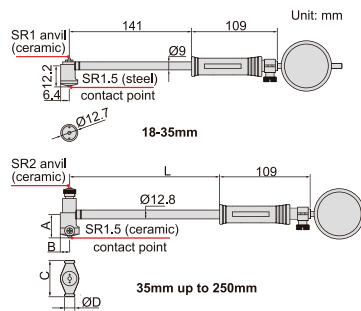

- ▶ Repeatability: 0.003mm
- ▶ Optional accessory: setting ring (code 6312), long handle (code 7351)

| Range     | A    | B  | C    | ØD | L   |
|-----------|------|----|------|----|-----|
| 35-60mm   | 22   | 9  | 27   | 13 | 141 |
| 50-160mm  | 26   | 9  | 35   | 13 | 141 |
| 160-250mm | 56.5 | 13 | 74.5 | 15 | 241 |

With dial indicator

| Code      | Range     | Indicator  | Accuracy | List Price (₹) | Promotion Price (₹) |
|-----------|-----------|--|----------|----------------|---------------------|
| 2322-35A  | 18-35mm   |  | ±0.015mm | 6490           | 4874                |
| 2322-60A  | 35-60mm   | dial indicator, range 10mm, graduation 0.01mm (code 2308-10FA) | ±0.018mm | 6483           | 4874                |
| 2322-160A | 50-160mm  |  | ±0.018mm | 6738           | 5060                |
| 2322-250A | 160-250mm |  | ±0.018mm | 9308           | 7248                |

## BORE GAGE SETS

- ▶ Repeatability: 0.003mm
- ▶ Optional accessory: setting ring (code 6312), long handle (code 7351)

packaging (code 2824-S3)



ATTENTION: NOT SUITABLE FOR 0.001MM DIAL INDICATORS

| Code      | Range    | Indicator   | Bore gages included  | Accuracy  | List Price (₹) | Promotion Price (₹) |
|-----------|----------|---|--|---|----------------|---------------------|
| 2824-S160 | 35-160mm |   | ① 35-50mm (dial indicator and handle are not included)<br>② 50-160mm                                   | 35-50mm ±0.018mm<br>50-160mm ±0.018mm                     | 9792           | 7179                |
| 2824-S3   | 18-160mm | dial indicator, range 10mm graduation 0.01mm (code 2308-10FA) | ① 18-35mm<br>② 35-60mm (dial indicator is not included)<br>③ 50-160mm (dial indicator is not included) | 18-35mm ±0.015mm<br>35-60mm ±0.018mm<br>50-160mm ±0.018mm | 18518          | 11710               |





TELESCOPING GAGE SET

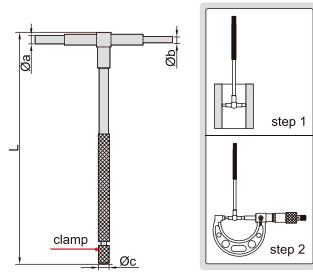

| Range     | L   | Øa  | Øb  | Øc  |
|-----------|-----|-----|-----|-----|
| 8-12.7mm  | 115 | 3.9 | 2.9 | 6.2 |
| 12.7-19mm | 115 | 5.3 | 3.8 | 6.2 |
| 19-32mm   | 115 | 5.3 | 3.8 | 6.2 |
| 32-54mm   | 137 | 7.6 | 6.1 | 7.2 |
| 54-90mm   | 137 | 7.6 | 6.1 | 7.2 |
| 90-150mm  | 137 | 7.6 | 6.1 | 7.2 |

4206-1

- 6 gages per set
- For quick measurement of inside diameter of holes and width of slots
- Satin chrome finish

| Code   | Total range | Gages included   | List Price (₹) | Promotion Price (₹) |
|--------|-------------|--|----------------|---------------------|
| 4206-1 | 8-150mm     | 8-12.7mm, 12.7-19mm<br>19-32mm, 32-54mm<br>54-90mm, 90-150mm | 1651           | 1333                |

DIGITAL INDICATORS (STANDARD MODEL)



spindle lift knob is included

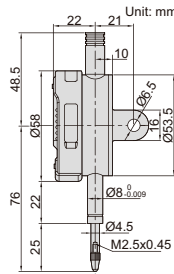

2112-10

- Range: 12.7mm/0.5"
- Button function: on/off, inch/mm, zero
- CR2032 battery, automatic power off
- With lug back
- Data output
- Optional accessory: data output cable, backs, contact points

| Code      | Resolution       | Accuracy | Hysteresis | List Price (₹) | Promotion Price (₹) |
|-----------|------------------|----------|------------|----------------|---------------------|
| 2112-10*  | 0.01mm/0.0005"   | 20µm     | 10µm       | 3914           | 3204                |
| 2112-101* | 0.001mm/0.00005" | 5µm      | 2µm        | 9511           | 8134                |

\*Supplied with manufacturer inspection certificate traceable to NIST USA

DIAL INDICATOR (PROMOTION MODEL)



2302-25

- Graduation: 0.01mm
- Range/rev: 1mm
- Dial reading: 0-100
- Lug back with spare flat back
- Supplied with limit pointers and bezel clamp
- Packed in carton box
- Optional accessory: backs, contact points

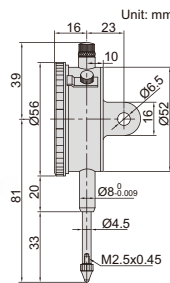

carton box



| Code     | Range | Accuracy | Hysteresis | List Price (₹) | Promotion Price (₹) |
|----------|-------|----------|------------|----------------|---------------------|
| 2302-25* | 25mm  | 35µm     | 7µm        | 2622           | 1923                |

\*Supplied with manufacturer inspection certificate traceable to NIST USA

DIGITAL INDICATORS (ADVANCED MODEL)



DATA OUTPUT

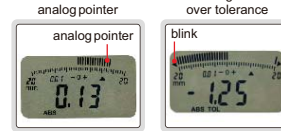

2103-10

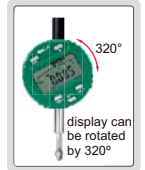
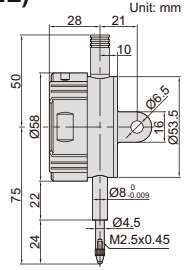

spindle lift knob is included



- Range: 12.7mm/0.5"
- Reading in digital and analog
- Display can be rotated by 320°
- Button function: tolerance Go and No-Go display, data preset, measuring direction change, max./min./TIR measurement, inch/metric conversion, absolute/incremental measurement
- Keep preset data and tolerance data in memory after restart
- CR2032 battery, automatic power off
- Data output, with lug back
- Optional accessory: data output cable, backs, contact points

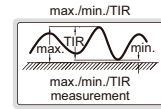

| Code     | Resolution       | Accuracy | Hysteresis | List Price (₹) | Promotion Price (₹) |
|----------|------------------|----------|------------|----------------|---------------------|
| 2103-10* | 0.001mm/0.00005" | 5µm      | 2µm        | 12543          | 10256               |
| 2104-10* | 0.01mm/0.0005"   | 20µm     | 10µm       | 5844           | 5061                |

\*Supplied with manufacturer inspection certificate traceable to NIST USA

PRECISION DIAL INDICATOR



JEWELLED BEARING



2313-1A

- Graduation: 0.001mm
- Jeweled bearing
- With lug back
- Supplied with limit pointers and bezel clamp
- Optional accessory: backs, contact points

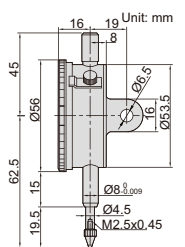

| Code     | Range | Accuracy | Hysteresis | Range/rev | Dial reading | List Price (₹) | Promotion Price (₹) |
|----------|-------|----------|------------|-----------|--------------|----------------|---------------------|
| 2313-1A* | 1mm   | 5µm      | 2µm        | 0.2mm     | 0-100-0      | 4493           | 3997                |

\*Supplied with manufacturer inspection certificate traceable to NIST USA

DIAL INDICATOR (PROMOTION MODEL)



2301-10

- Graduation: 0.01mm
- Range/rev: 1mm
- Dial reading: 0-100
- Meet DIN878
- Jeweled bearing
- Lug back with spare flat back
- Supplied with limit hands and bezel clamp
- Packed in carton box
- Optional accessory: backs, contact points

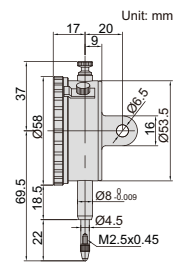

carton box



| Code     | Range | Accuracy | Hysteresis | List Price (₹) | Promotion Price (₹) |
|----------|-------|----------|------------|----------------|---------------------|
| 2301-10* | 10mm  | 17µm     | 3µm        | 1377           | 1145                |

\*Supplied with manufacturer inspection certificate traceable to NIST USA

### DIAL TEST INDICATORS

**JEWELLED BEARING**

- ▶ Meet DIN2270 (except 2380-02, 2381-02)
- ▶ Jeweled bearing
- ▶ Carbide contact point
- ▶ Two measuring directions
- ▶ Anti magnetic body
- ▶ Supplied with two clamps: diameter Ø4mm and Ø8mm
- ▶ Optional accessory: styli



2380-08

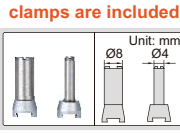

clamps are included

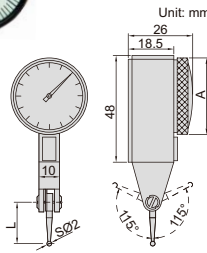

**INSPECTION CERTIFICATE**  
TRACEABLE TO NIST

Graduation: 0.01mm

(mm)

| Code     | Range | Accuracy | Hysteresis | Dial reading | A   | L    | List Price (₹) | Promotion Price (₹) |
|----------|-------|----------|------------|--------------|-----|------|----------------|---------------------|
| 2380-08* | 0.8mm | 13µm     | 3µm        | 0-40-0       | Ø30 | 13.5 | 2618           | 2160                |
| 2381-08* | 0.8mm | 13µm     | 3µm        | 0-40-0       | Ø37 | 13.5 | 2862           | 2513                |

Graduation: 0.002mm

(mm)

| Code     | Range | Accuracy | Hysteresis | Dial reading | A   | L    | List Price (₹) | Promotion Price (₹) |
|----------|-------|----------|------------|--------------|-----|------|----------------|---------------------|
| 2380-02* | 0.2mm | 6µm      | 2µm        | 0-100-0      | Ø30 | 12.5 | 4720           | 4327                |
| 2381-02* | 0.2mm | 6µm      | 2µm        | 0-100-0      | Ø37 | 12.5 | 4915           | 4377                |

\*Supplied with manufacturer inspection certificate traceable to NIST USA

### MAGNETIC STANDS

- ▶ Applicable holding stem: Ø8mm, Ø4mm, 3/8" DIA.
- ▶ For digital/dial indicators and dial test indicators

| Code    | Magnetic force | Remark                  | List Price (₹) | Promotion Price (₹) |
|---------|----------------|-------------------------|----------------|---------------------|
| 6200-60 | 60kgf          | without fine adjustment | 1086           | 922                 |
| 6201-60 | 60kgf          | with fine adjustment    | 1006           | 854                 |
| 6202-80 | 80kgf          | with fine adjustment    | 1964           | 1361                |

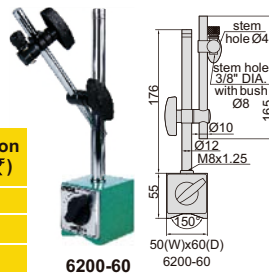

6200-60

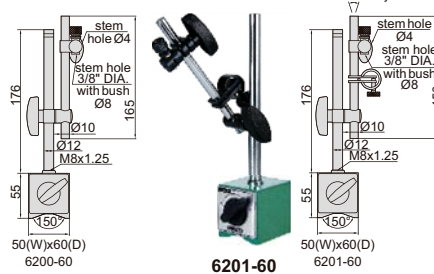

6201-60

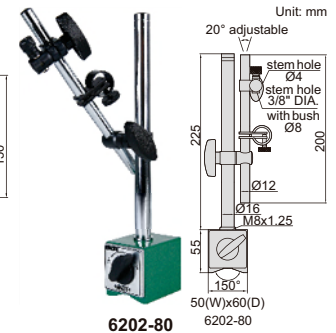

6202-80

### UNIVERSAL MAGNETIC STAND (LIGHT DUTY)

**ATTENTION: LOW LOCKING FORCE**

- ▶ Applicable holding stem: Ø8mm
- ▶ For digital/dial indicators and dial test indicators
- ▶ With fine adjustment and dovetail groove

| Code     | Magnetic force | List Price (₹) | Promotion Price (₹) |
|----------|----------------|----------------|---------------------|
| 6208-80A | 80kgf          | 2554           | 2068                |

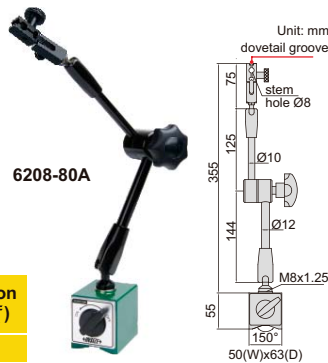

6208-80A

### UNIVERSAL MAGNETIC STAND

- ▶ Applicable holding stem: Ø8mm
- ▶ For digital/dial indicators and dial test indicators
- ▶ With fine adjustment and dovetail groove

| Code    | Magnetic force | List Price (₹) | Promotion Price (₹) |
|---------|----------------|----------------|---------------------|
| 6210-80 | 80kgf          | 4797           | 4205                |

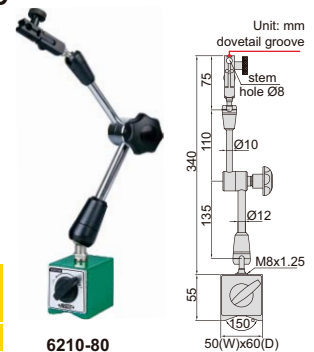

6210-80

### DIAL TEST INDICATOR CENTERING HOLDER



- ▶ Center cylinders or holes on machine tools

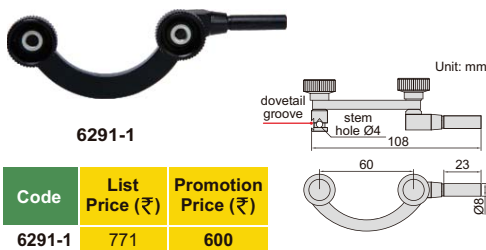

6291-1

| Code   | List Price (₹) | Promotion Price (₹) |
|--------|----------------|---------------------|
| 6291-1 | 771            | 600                 |

### MINI MAGNETIC STAND

**ATTENTION: FOR DIAL TEST INDICATORS ONLY**

- ▶ For dial test indicators
- ▶ With dovetail groove
- ▶ Applicable holding stem: Ø6mm, Ø8mm

| Code    | Magnetic force | List Price (₹) | Promotion Price (₹) |
|---------|----------------|----------------|---------------------|
| 6211-10 | 10kgf          | 1912           | 1458                |

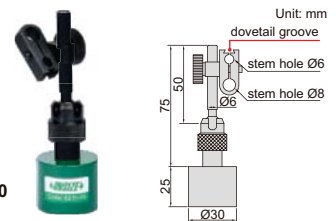

6211-10

### INTERNAL DIAL CALIPER GAGES

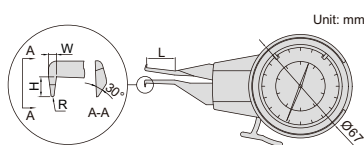

2222-15

- ▶ Graduation: 0.01mm
- ▶ Accuracy: ±0.03mm

| Code     | Range   | L  | H   | W   | R    | List Price (₹) | Promotion Price (₹) |
|----------|---------|----|-----|-----|------|----------------|---------------------|
| 2222-15  | 5-15mm  | 20 | 2   | 1.5 | R0.3 | 9948           | 8507                |
| 2222-25  | 5-25mm  | 35 | 1.5 | 1.0 | R0.3 | 10789          | 9226                |
| 2222-301 | 10-30mm | 55 | 5.5 | 2.5 | R0.5 | 11910          | 10186               |

THICKNESS GAGES

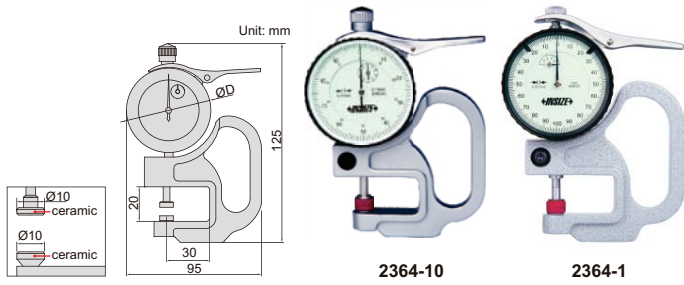

| Code    | Range  | Graduation | Accuracy | ØD   | List Price (₹) | Promotion Price (₹) |
|---------|--------|------------|----------|------|----------------|---------------------|
| 2364-10 | 0-10mm | 0.01mm     | ±0.02mm  | 58mm | 3338           | 2966                |
| 2364-1  | 0-1mm  | 0.001mm    | ±0.005mm | 56mm | 6204           | 5535                |

THICKNESS GAGE

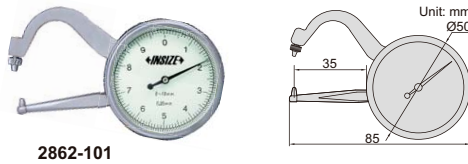

| Code     | Range  | Graduation | Accuracy | List Price (₹) | Promotion Price (₹) |
|----------|--------|------------|----------|----------------|---------------------|
| 2862-101 | 0-10mm | 0.05mm     | ±0.1mm   | 2905           | 2173                |

PIN GAGE SETS

- ▶ Meet DIN2267, grade 1
- ▶ Made of alloy steel
- ▶ Hardness HRC62-65
- ▶ Diameter accuracy: ±1µm



| Code     | Diameter Ød (mm)        | Step  | Pin gages per set | List Price (₹) | Promotion Price (₹) |
|----------|-------------------------|-------|-------------------|----------------|---------------------|
| 4166-411 | 1.0, 1.1, 1.2, ... 5.0  | 0.1mm | 41                | 9745           | 7377                |
| 4166-511 | 5.0, 5.1, 5.2, ... 10.0 | 0.1mm | 51                | 13235          | 10020               |

| Code    | Diameter Ød (mm)            | Step   | Pin gages per set | List Price (₹) | Promotion Price (₹) |
|---------|-----------------------------|--------|-------------------|----------------|---------------------|
| 4166-0D | 0.20, 0.21, 0.22, ... 0.50  | 0.01mm | 31                | 9514           | 7203                |
| 4166-1  | 0.50, 0.51, 0.52, ... 1.00  | 0.01mm | 51                | 14767          | 11179               |
| 4166-1D | 1.00, 1.01, 1.02, ... 1.50  | 0.01mm | 51                | 14767          | 11179               |
| 4166-2  | 1.50, 1.51, 1.52, ... 2.00  | 0.01mm | 51                | 14767          | 11179               |
| 4166-2D | 2.00, 2.01, 2.02, ... 2.50  | 0.01mm | 51                | 14767          | 11179               |
| 4166-3  | 2.50, 2.51, 2.52, ... 3.00  | 0.01mm | 51                | 14767          | 11179               |
| 4166-3D | 3.00, 3.01, 3.02, ... 3.50  | 0.01mm | 51                | 14767          | 11179               |
| 4166-4  | 3.50, 3.51, 3.52, ... 4.00  | 0.01mm | 51                | 14767          | 11179               |
| 4166-4D | 4.00, 4.01, 4.02, ... 4.50  | 0.01mm | 51                | 14767          | 11179               |
| 4166-5  | 4.50, 4.51, 4.52, ... 5.00  | 0.01mm | 51                | 14767          | 11179               |
| 4166-5D | 5.00, 5.01, 5.02, ... 5.50  | 0.01mm | 51                | 14767          | 11179               |
| 4166-6  | 5.50, 5.51, 5.52, ... 6.00  | 0.01mm | 51                | 14767          | 11179               |
| 4166-6D | 6.00, 6.01, 6.02, ... 6.50  | 0.01mm | 51                | 14767          | 11179               |
| 4166-7  | 6.50, 6.51, 6.52, ... 7.00  | 0.01mm | 51                | 14767          | 11179               |
| 4166-7D | 7.00, 7.01, 7.02, ... 7.50  | 0.01mm | 51                | 14767          | 11179               |
| 4166-8  | 7.50, 7.51, 7.52, ... 8.00  | 0.01mm | 51                | 14767          | 11179               |
| 4166-8D | 8.00, 8.01, 8.02, ... 8.50  | 0.01mm | 51                | 14767          | 11179               |
| 4166-9  | 8.50, 8.51, 8.52, ... 9.00  | 0.01mm | 51                | 14784          | 11193               |
| 4166-9D | 9.00, 9.01, 9.02, ... 9.50  | 0.01mm | 51                | 15630          | 11834               |
| 4166-10 | 9.50, 9.51, 9.52, ... 10.00 | 0.01mm | 51                | 15682          | 11872               |

DIGITAL THICKNESS GAGES

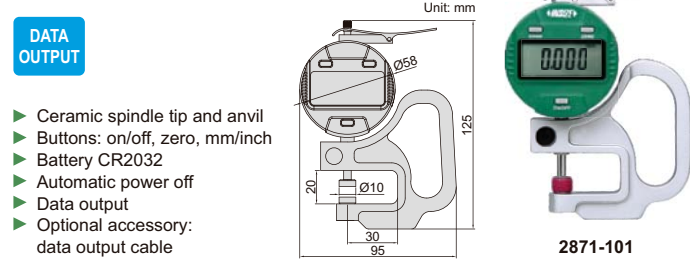

DATA OUTPUT

- ▶ Ceramic spindle tip and anvil
- ▶ Buttons: on/off, zero, mm/inch
- ▶ Battery CR2032
- ▶ Automatic power off
- ▶ Data output
- ▶ Optional accessory: data output cable

| Code     | Range         | Resolution       | Accuracy | List Price (₹) | Promotion Price (₹) |
|----------|---------------|------------------|----------|----------------|---------------------|
| 2871-10  | 0-10mm/0-0.4" | 0.01mm/0.0005"   | ±0.02mm  | 5761           | 5267                |
| 2871-101 | 0-10mm/0-0.4" | 0.001mm/0.00005" | ±0.005mm | 12491          | 10299               |

STEEL GAGE BLOCK SETS

- ▶ Made of alloy steel
- ▶ Meet ISO3650
- ▶ With holes (L≥125mm)
- ▶ Supplied with manufacturer inspection certificate

INSPECTION CERTIFICATE

Dimension:

| Size (L)       | W   | H    |
|----------------|-----|------|
| 0.5 ≤ L < 10mm | 9mm | 30mm |
| L > 10mm       | 9mm | 35mm |

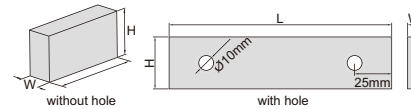

4100-283

| Blocks per set | Gage blocks included in set |           |          | Code      | List Price (₹) | Promotion Price (₹) |
|----------------|-----------------------------|-----------|----------|-----------|----------------|---------------------|
|                | Size (mm)                   | Step (mm) | Quantity |           |                |                     |
| 112            | 1.0005                      |           | 1        | 4100-2112 | 27407          | 19976               |
|                | 1.001-1.009                 | 0.001     | 9        |           |                |                     |
|                | 1.01-1.49                   | 0.01      | 49       |           |                |                     |
|                | 0.5-24.5                    | 0.5       | 49       |           |                |                     |
|                | 25-100                      | 25        | 4        |           |                |                     |
| 83             | 0.5                         |           | 1        | 4100-283  | 17278          | 11194               |
|                | 1                           |           | 1        |           |                |                     |
|                | 1.005                       |           | 1        |           |                |                     |
|                | 1.01-1.49                   | 0.01      | 49       |           |                |                     |
|                | 1.5-1.9                     | 0.1       | 5        |           |                |                     |
|                | 2-9.5                       | 0.5       | 16       |           |                |                     |
|                | 10-100                      | 10        | 10       |           |                |                     |
| 34             | 1.0005                      |           | 1        | 4100-234  | 8279           | 5606                |
|                | 1.001-1.009                 | 0.001     | 9        |           |                |                     |
|                | 1.01-1.09                   | 0.01      | 9        |           |                |                     |
|                | 1.1-1.9                     | 0.1       | 9        |           |                |                     |
|                | 1-5                         | 1         | 5        |           |                |                     |
|                | 10                          |           | 1        |           |                |                     |

DIGITAL PROTRACTORS

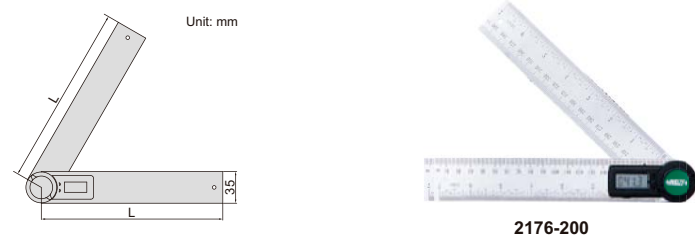

- ▶ Accuracy: ±0.3°
- ▶ Buttons: on/off, zero
- ▶ With clamping screw to lock the blades
- ▶ Graduation of blade: 1mm and 1/32"
- ▶ Made of stainless steel
- ▶ CR2032 battery, automatic power off

| Code     | Size (L) | Range  | Resolution | List Price (₹) | Promotion Price (₹) |
|----------|----------|--------|------------|----------------|---------------------|
| 2176-200 | 200mm    | 0-360° | 0.1°       | 2027           | 1528                |
| 2176-300 | 300mm    | 0-360° | 0.1°       | 2329           | 1755                |

**PROTRACTOR**



- ▶ Graduation: 1°
- ▶ Made of stainless steel
- ▶ Satin chrome plated scale
- ▶ With clamping screw

| Code     | Size (AxB) | Range  | Accuracy | L   | C  | List Price (₹) | Promotion Price (₹) |
|----------|------------|--------|----------|-----|----|----------------|---------------------|
| 4799-180 | 80x120     | 0-180° | ±0.3°    | 168 | 11 | 1257           | 1005                |

**UNIVERSAL PROTRACTOR**

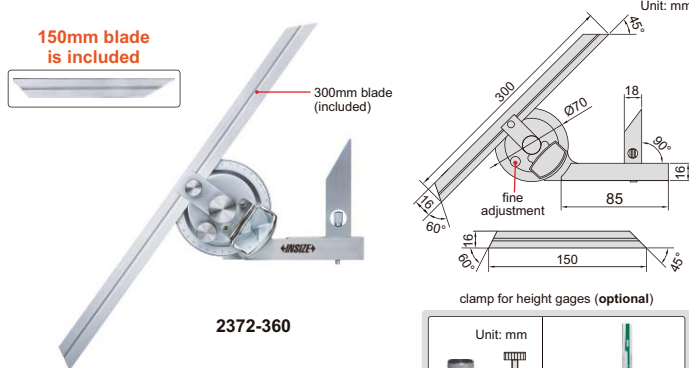

- ▶ Parallax-free reading
- ▶ Made of stainless steel
- ▶ Optional accessory: clamp (code 2372-CLAMP), suitable for height gages 1156, 1351 and 1250

| Code     | Range  | Graduation | Accuracy | List Price (₹) | Promotion Price (₹) |
|----------|--------|------------|----------|----------------|---------------------|
| 2372-360 | 0-360° | 5'         | ±5'      | 4667           | 3847                |

**90° BEVELED EDGE SQUARES**

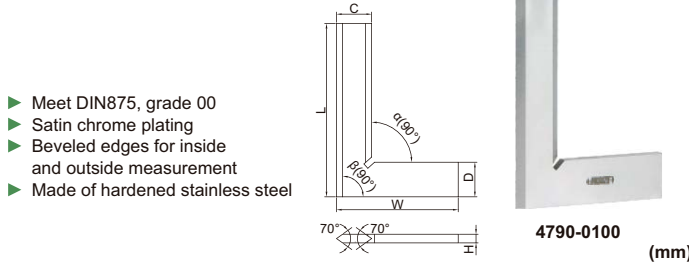

- ▶ Meet DIN875, grade 00
- ▶ Satin chrome plating
- ▶ Beveled edges for inside and outside measurement
- ▶ Made of hardened stainless steel

| Code      | Size (LxW) | Squareness |             | C  | D  | H | List Price (₹) | Promotion Price (₹) |
|-----------|------------|------------|-------------|----|----|---|----------------|---------------------|
|           |            | Inside (α) | Outside (β) |    |    |   |                |                     |
| 4790-0100 | 100x70mm   | 2.8μm      | 3.0μm       | 20 | 20 | 5 | 2339           | 2019                |
| 4790-0150 | 150x100mm  | 3.2μm      | 3.5μm       | 30 | 30 | 6 | 4004           | 3527                |

**DIGITAL PROTRACTOR**

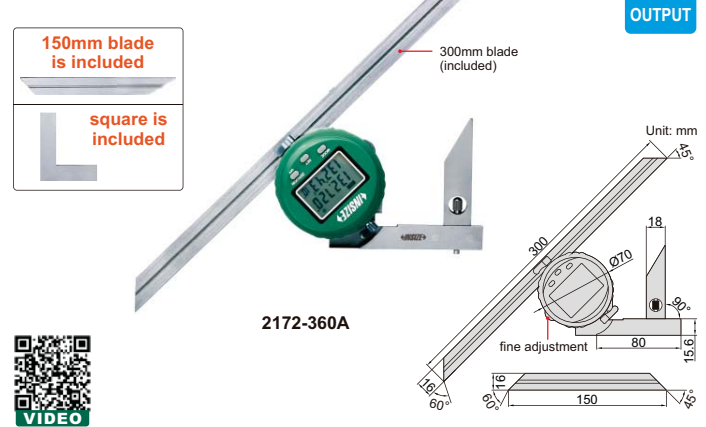

- ▶ Display in degree (for example 32.655°) and degree/minute/second (for example 32°39'30")
- ▶ SET button: preset the reading, change measuring direction
- ▶ MODE button: choose 0-90°, 0-180° or 0-360° display
- ▶ ZERO/ON/OFF button: zero and power on/off
- ▶ Battery CR2032, automatic power off
- ▶ Data output
- ▶ Supplied with square to set 90°
- ▶ Made of stainless steel
- ▶ Optional accessory: data output cable, clamp (code 2372-CLAMP), suitable for height gages 1156, 1351 and 1250

| Code      | Range  | Resolution | Accuracy | List Price (₹) | Promotion Price (₹) |
|-----------|--------|------------|----------|----------------|---------------------|
| 2172-360A | 0-360° | 10"/0.005° | ±5'      | 20514          | 16584               |

**TRY SQUARE**

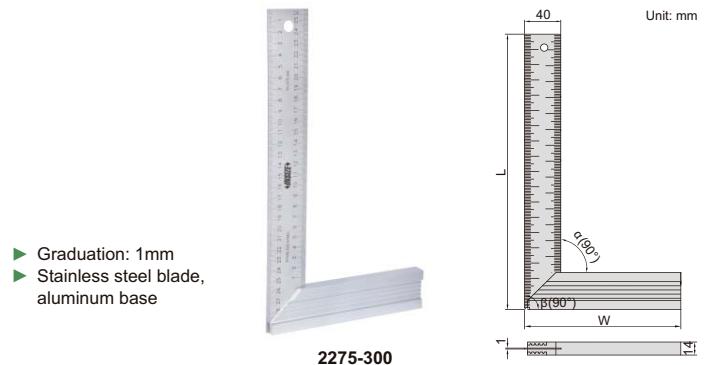

- ▶ Graduation: 1mm
- ▶ Stainless steel blade, aluminum base

| Code     | Size (LxW) | Squareness |             | List Price (₹) | Promotion Price (₹) |
|----------|------------|------------|-------------|----------------|---------------------|
|          |            | Inside (α) | Outside (β) |                |                     |
| 2275-300 | 300x170mm  | 0.5mm      | 0.5mm       | 487            | 407                 |

**FEELER GAGES**

- ▶ Made of hardened alloy steel
- ▶ Meet DIN2275
- ▶ Accuracy: ±(3+T/80) μm, 'T' is the thickness of leaves in μm

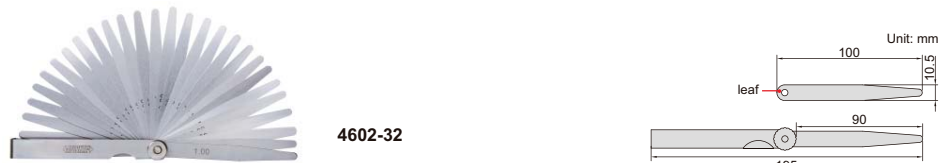

| Code    | Range       | Thickness of leaves included (mm)  | Quantity of leaves | List Price (₹) | Promotion Price (₹) |
|---------|-------------|--|--------------------|----------------|---------------------|
| 4602-17 | 0.02-1.00mm | 0.02, 0.03, 0.04, 0.05, 0.06, 0.07, 0.08, 0.09, 0.10, 0.15, 0.20, 0.25, 0.30, 0.40, 0.50, 0.75, 1.00   | 17                 | 313            | 252                 |
| 4602-32 | 0.03-1.00mm | 0.03, 0.04, 0.05, 0.06, 0.07, 0.08, 0.09, 0.10, 0.13, 0.15, 0.18, 0.20, 0.23, 0.25, 0.28, 0.30, 0.33, 0.35, 0.38, 0.40, 0.45, 0.50, 0.55, 0.60, 0.63, 0.65, 0.70, 0.75, 0.80, 0.85, 0.90, 1.00 | 32                 | 480            | 342                 |

PITCH GAGES

- ▶ Check the pitch of screw thread
- ▶ Accuracy:  $\pm 0.07\text{mm}$
- ▶ Made of medium carbon steel



4820-452

ATTENTION:  
LOW ACCURACY

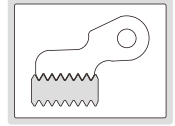

Metric 60° and Whitworth 55° screw

| Code     | Range    | Pitch of leaves included   | Quantity of leaves | List Price (₹) | Promotion Price (₹) |
|----------|----------|--|--------------------|----------------|---------------------|
| 4820-452 | 0.25-6mm | 0.25, 0.3, 0.35, 0.4, 0.45, 0.5, 0.6, 0.7, 0.75, 0.8, 0.9, 1, 1.25, 1.5, 1.75, 2, 2.5, 3, 3.5, 4, 4.5, 5, 5.5, 6mm | 52                 | 627            | 489                 |
|          | 4-62TPI  | 4, 4-1/2, 5, 6, 7, 8, 9, 10, 11, 12, 13, 14, 16, 18, 19, 20, 22, 24, 25, 26, 28, 30, 32, 36, 40, 48, 60, 62TPI     |                    |                |                     |

Metric 60° and Unified 60° screw

| Code     | Range   | Pitch of leaves included  | Quantity of leaves | List Price (₹) | Promotion Price (₹) |
|----------|---------|---|--------------------|----------------|---------------------|
| 4820-552 | 0.4-7mm | 0.4, 0.5, 0.6, 0.7, 0.75, 0.8, 0.9, 1, 1.25, 1.5, 1.75, 2, 2.5, 3, 3.5, 4, 4.5, 5, 5.5, 6, 6.5, 7mm                           | 52                 | 627            | 460                 |
|          | 4-42TPI | 4, 4-1/2, 5, 5-1/2, 6, 7, 8, 9, 10, 11, 11-1/2, 12, 13, 14, 15, 16, 18, 20, 22, 24, 26, 27, 28, 30, 32, 34, 36, 38, 40, 42TPI |                    |                |                     |

RADIUS GAGES

- ▶ Made of medium carbon steel



4801-17

ATTENTION:  
LOW ACCURACY

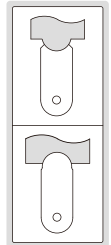

| Code    | Range     | Radius of leaves included (mm)  | Quantity of leaves (internal+external) | Accuracy             | List Price (₹) | Promotion Price (₹) |
|---------|-----------|---|--|----------------------|----------------|---------------------|
| 4801-17 | 1-7mm     | 1, 1.25, 1.5, 1.75, 2, 2.25, 2.5, 2.75, 3, 3.5, 4, 4.5, 5, 5.5, 6, 6.5, 7 | 17+17                                  | $\pm 0.03\text{mm}$  | 684            | 547                 |
| 4801-16 | 7.5-15mm  | 7.5, 8, 8.5, 9, 9.5, 10, 10.5, 11, 11.5, 12, 12.5, 13, 13.5, 14, 14.5, 15 | 16+16                                  | $\pm 0.035\text{mm}$ | 680            | 542                 |
| 4801-15 | 15.5-25mm | 15.5, 16, 16.5, 17, 17.5, 18, 18.5, 19, 19.5, 20, 21, 22, 23, 24, 25      | 15+15                                  | $\pm 0.042\text{mm}$ | 691            | 560                 |

TAPER GAGE

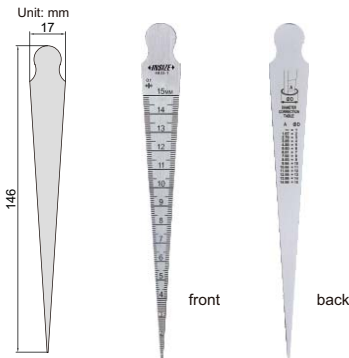

4833-1

- ▶ Measure opening, slot width, hole diameter, etc.
- ▶ Diameter correction table on the back
- ▶ Made of stainless steel

measure slot width

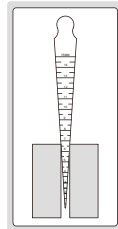

measure diameter of hole

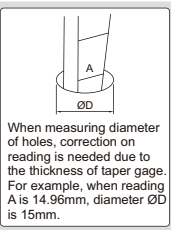

| Code   | Range    | Graduation | Accuracy           | List Price (₹) | Promotion Price (₹) |
|--------|----------|------------|--------------------|----------------|---------------------|
| 4833-1 | 0.8-15mm | 0.1mm      | $\pm 0.1\text{mm}$ | 631            | 350                 |

TAPER GAGE SET



front

4837-1

back

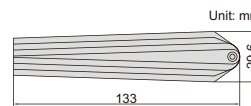

- ▶ Include 4pcs (1-8mm, 8-15mm, 15-22mm, 22-29mm)
- ▶ Measure opening, slot width, hole diameter, etc.
- ▶ Diameter correction table on the back
- ▶ Made of stainless steel

| Code   | Range  | Graduation | Accuracy            | List Price (₹) | Promotion Price (₹) |
|--------|--------|------------|---------------------|----------------|---------------------|
| 4837-1 | 1-29mm | 0.05mm     | $\pm 0.05\text{mm}$ | 2332           | 1339                |

measure slot width

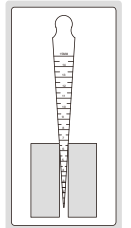

measure diameter of hole

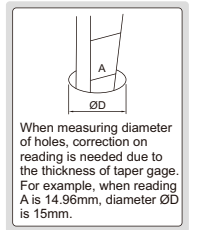

FILLET WELDING GAGE

- ▶ Measure concave and convex weld sizes
- ▶ 7 blades are included
- ▶ Made of stainless steel

| Code   | Size (mm)  | Accuracy           | List Price (₹) | Promotion Price (₹) |
|--------|--|--------------------|----------------|---------------------|
| 4836-1 | 3, 4, 5, 6, 8, 9, 10, 11, 12, 14, 16, 19, 22, 25 | $\pm 0.5\text{mm}$ | 1472           | 1021                |

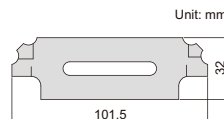

4836-1

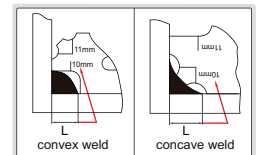

## FILLET WELDING GAGE

- ▶ Accuracy:  $\pm 0.5\text{mm}$
- ▶ Made of stainless steel
- ▶ Sizes marked on both faces

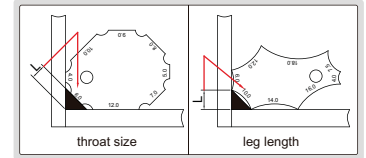
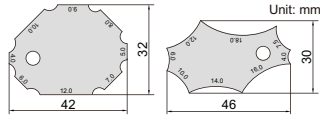

| Code   | Throat size                | Leg length                      | List Price (₹) | Promotion Price (₹) |
|--------|----------------------------|---------------------------------|----------------|---------------------|
| 4832-1 | 4, 5, 6, 7, 8, 9, 10, 12mm | 4, 6, 7.5, 10, 12, 14, 16, 18mm | 623            | 400                 |

## WELDING GAGE

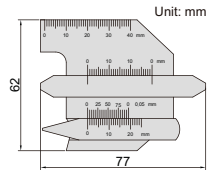

- ▶ Made of stainless steel

| Code   | Measurement    | Range    | Graduation | Accuracy            | List Price (₹) | Promotion Price (₹) |
|--------|----------------|----------|------------|---------------------|----------------|---------------------|
| 4838-1 | crown height   | 0-10mm   | 1mm        | $\pm 0.5\text{mm}$  | 2028           | 1576                |
|        | leg height     | 0-14mm   | 1mm        | $\pm 0.5\text{mm}$  |                |                     |
|        | undercut depth | 0-5mm    | 0.05mm     | $\pm 0.05\text{mm}$ |                |                     |
|        | throat size    | 0-13mm   | 1mm        | $\pm 0.5\text{mm}$  |                |                     |
|        | weld length    | 0-40mm   | 1mm        | $\pm 1\text{mm}$    |                |                     |
|        | angle          | 90°-150° | 5°         | $\pm 1^\circ$       |                |                     |
|        | gap            | 0.5-5mm  | 1mm        | $\pm 0.5\text{mm}$  |                |                     |
|        | length         | 0-40mm   | 1mm        | $\pm 0.5\text{mm}$  |                |                     |

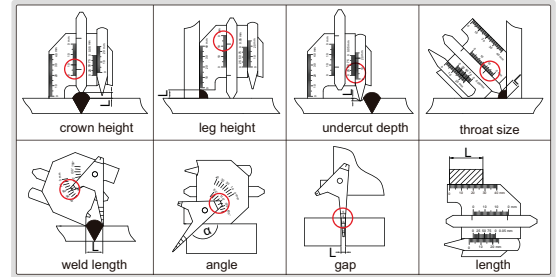

## WELDING GAGE

- ▶ Adjustable scale to compensate pointer wear
- ▶ Made of stainless steel

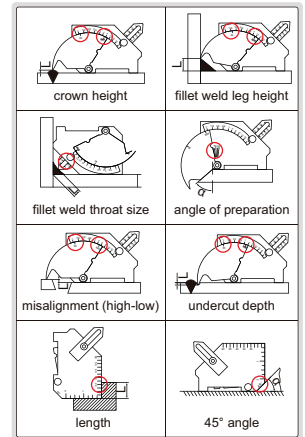
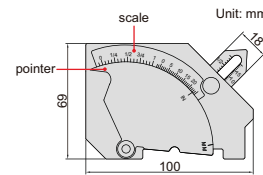

| Code   | Measurement             | Range           | Graduation  | Accuracy           | List Price (₹) | Promotion Price (₹) |
|--------|-------------------------|-----------------|-------------|--------------------|----------------|---------------------|
| 4835-1 | crown height            | 0-25mm (0-1")   | 1mm (1/16") | $\pm 0.5\text{mm}$ | 2042           | 1447                |
|        | fillet weld leg height  | 0-25mm (0-1")   | 1mm (1/16") | $\pm 0.5\text{mm}$ |                |                     |
|        | misalignment (high-low) | 0-25mm (0-1")   | 1mm (1/16") | $\pm 0.5\text{mm}$ |                |                     |
|        | undercut depth          | 0-2mm (0-1/8")  | 1mm (1/16") | $\pm 0.5\text{mm}$ |                |                     |
|        | fillet weld throat size | 0-20mm (0-3/4") | 1mm (1/16") | $\pm 0.5\text{mm}$ |                |                     |
|        | angle of preparation    | 0-60°           | 5°          | $\pm 1^\circ$      |                |                     |
|        | length                  | 0-60mm (0-2")   | 1mm (1/16") | $\pm 0.5\text{mm}$ |                |                     |
|        | 45° angle               | —               | —           | $\pm 1^\circ$      |                |                     |

## PIPE WELDING GAGE

- ▶ Made of stainless steel

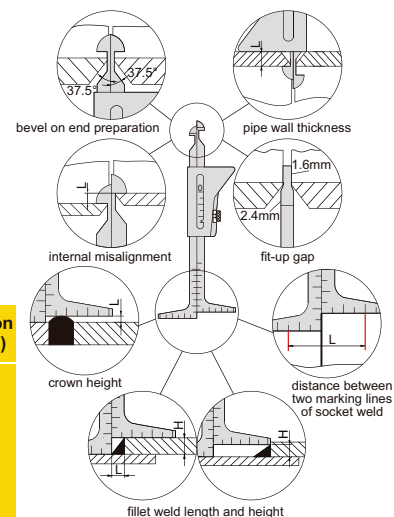
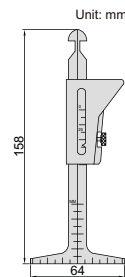

| Code   | Measurement                                       | Range             | Graduation  | Accuracy           | List Price (₹) | Promotion Price (₹) |
|--------|---|-------------------|-------------|--------------------|----------------|---------------------|
| 4839-1 | bevel on end preparation                          | 37.5°             | —           | $\pm 1^\circ$      | 2939           | 2036                |
|        | pipe wall thickness                               | 0-45mm (0~1-3/4") | 1mm (1/16") | $\pm 0.5\text{mm}$ |                |                     |
|        | internal misalignment                             | 0-35mm (0~1-3/8") | 1mm (1/32") | $\pm 0.5\text{mm}$ |                |                     |
|        | fit-up gap  | 1.6mm, 2.4mm      | —           | $\pm 0.1\text{mm}$ |                |                     |
|        | crown height                                      | 0-35mm (0~1-3/8") | 1mm (1/32") | $\pm 0.5\text{mm}$ |                |                     |
|        | distance between two marking lines of socket weld | 0-60mm (0~2-3/8") | 1mm (1/16") | $\pm 0.5\text{mm}$ |                |                     |
|        | fillet weld length                                | 0-30mm (0~1-1/4") | 1mm (1/16") | $\pm 0.5\text{mm}$ |                |                     |
|        | fillet weld height                                | 0-35mm (0~1-3/8") | 1mm (1/32") | $\pm 0.5\text{mm}$ |                |                     |

**INSIDE SPRING CALIPERS**

► Made of carbon steel

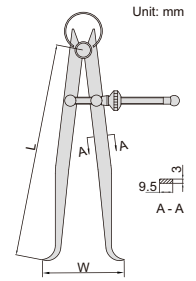
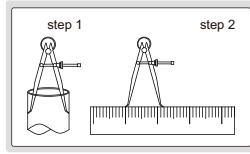

| Code     | Size (L) | Range (W) | List Price (₹) | Promotion Price (₹) |
|----------|----------|-----------|----------------|---------------------|
| 7261-150 | 150mm    | 20-170mm  | 588            | 546                 |
| 7261-200 | 200mm    | 22-220mm  | 671            | 637                 |
| 7261-300 | 300mm    | 30-320mm  | 1014           | 964                 |

7261-150

**SPRING DIVIDERS**

► Made of carbon steel  
► Hardened points

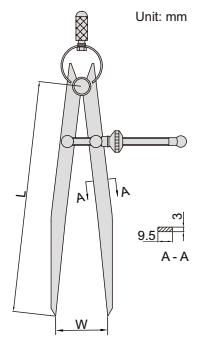
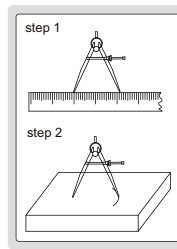

| Code     | Size (L) | Range (W) | List Price (₹) | Promotion Price (₹) |
|----------|----------|-----------|----------------|---------------------|
| 7260-150 | 150mm    | 0-150mm   | 588            | 546                 |
| 7260-200 | 200mm    | 0-210mm   | 671            | 637                 |
| 7260-300 | 300mm    | 0-320mm   | 1014           | 964                 |

7260-150

**OUTSIDE SPRING CALIPERS**

► Made of carbon steel

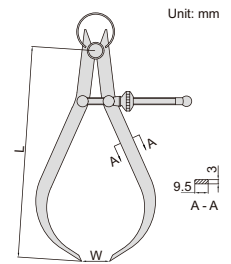
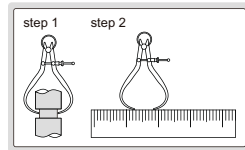

| Code     | Size (L) | Range (W) | List Price (₹) | Promotion Price (₹) |
|----------|----------|-----------|----------------|---------------------|
| 7262-150 | 150mm    | 0-140mm   | 588            | 546                 |
| 7262-200 | 210mm    | 0-210mm   | 671            | 637                 |
| 7262-300 | 310mm    | 0-320mm   | 1093           | 1038                |

7262-150

**STEEL RULES**

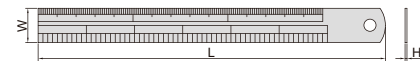

ATTENTION:  
BASIC MODEL

7110-300

► Graduation: 0.5mm, 1mm, 1/64", 1/32", 1/16"  
► Rigid rules  
► Made of stainless steel  
► Non-glare surface  
► Graduation on front and back

| Code      | Range      | Accuracy | L    | W  | H   | List Price (₹) | Promotion Price (₹) |
|-----------|------------|----------|------|----|-----|----------------|---------------------|
| 7110-150  | 150mm/6"   | ±0.15mm  | 170  | 18 | 1.0 | 77             | 67                  |
| 7110-300  | 300mm/12"  | ±0.15mm  | 330  | 25 | 1.0 | 135            | 119                 |
| 7110-500  | 500mm/20"  | ±0.15mm  | 530  | 30 | 1.2 | 282            | 241                 |
| 7110-600  | 600mm/24"  | ±0.20mm  | 630  | 30 | 1.2 | 318            | 272                 |
| 7110-1000 | 1000mm/40" | ±0.20mm  | 1040 | 32 | 1.5 | 632            | 542                 |

**ALUMINUM RULE**

► Graduation: 1mm  
► Made of aluminum, oxidized surface

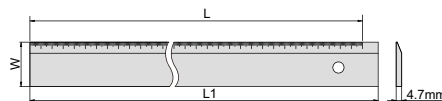

7123-600

| Code     | Range (L) | Accuracy | L1    | W    | List Price (₹) | Promotion Price (₹) |
|----------|-----------|----------|-------|------|----------------|---------------------|
| 7123-600 | 600mm     | ±0.9mm   | 624mm | 50mm | 470            | 423                 |

## LIGHT DUTY COMBINATION SQUARE

- ▶ Square head (made of zinc):  
To set the blade at 90° or 45° to an edge of a workpiece  
Accuracy: ±0.5°
- ▶ Blade (made of stainless steel):  
Range: 300mm/12",  
Graduation: 1mm and 1/32" on front face, 1mm and 1/16" on back face



2276-300

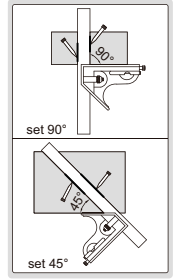
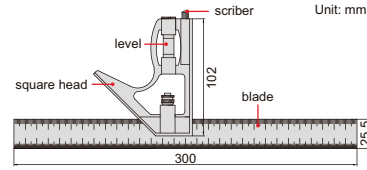

| Code     | List Price (₹) | Promotion Price (₹) |
|----------|----------------|---------------------|
| 2276-300 | 482            | 406                 |

## COMBINATION SQUARE SET

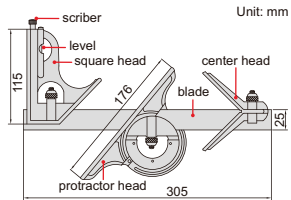

2278-180

- ▶ Center head (made of cast iron):  
To locate center of cylinder with diameter (Ød): 30-100mm  
Accuracy: ±0.15mm
- ▶ Protractor head (made of cast iron):  
To set the blade at desired angle to an edge of a workpiece, and can be used to measure angles  
Range: 0-180°  
Accuracy: ±7min.
- ▶ Square head (made of cast iron):  
To set the blade at 90° or 45° to an edge of a workpiece  
Accuracy: ±8min for 90° square, ±10min for 45° square
- ▶ Blade (made of stainless steel):  
Range: 300mm/12",  
Graduation: 0.5mm and 1/32" on front face, 1mm and 1/64" on back face
- ▶ Optional accessory: rigid rule (code 7113)

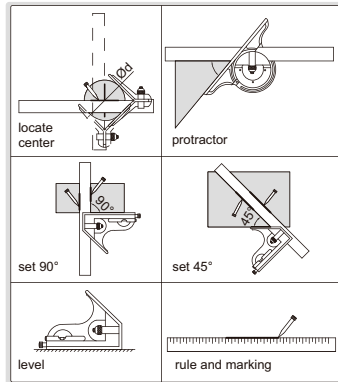

| Code     | Remark      | List Price (₹) | Promotion Price (₹) |
|----------|-------------|----------------|---------------------|
| 2278-180 | 4-piece set | 5978           | 4825                |

## MEASURING WHEEL



- ▶ ABS plastic frame, wear-resistant PU tire
- ▶ Two-section foldable handle

| Code   | Range       | Resolution | List Price (₹) | Promotion Price (₹) |
|--------|-------------|------------|----------------|---------------------|
| 7145-1 | 0.1-9999.9m | 0.1m       | 6490           | 5841                |

## MEASURING WHEEL

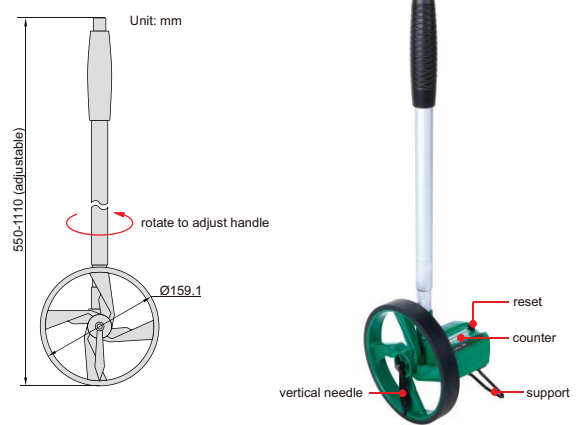

7144-1

- ▶ ABS plastic frame, wear-resistant PU tire
- ▶ Three-section adjustable handle

| Code   | Range       | Resolution | List Price (₹) | Promotion Price (₹) |
|--------|-------------|------------|----------------|---------------------|
| 7144-1 | 0.1-9999.9m | 0.1m       | 2869           | 2582                |

## CENTERING INDICATOR

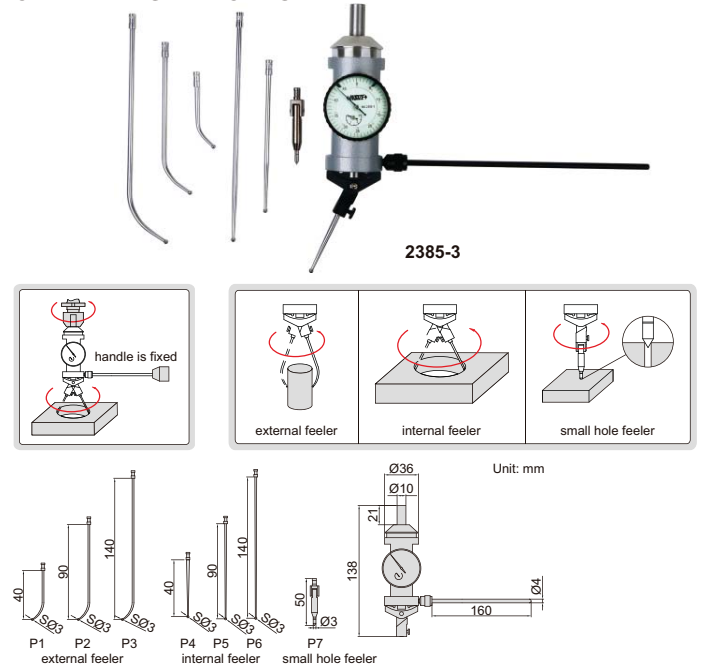

2385-3

- ▶ Provides quick and accurate centering in boring and milling set-up

| Code   | List Price (₹) | Promotion Price (₹) |
|--------|----------------|---------------------|
| 2385-3 | 8785           | 6435                |

| Feeler | Measuring diameter | Accuracy |
|--------|--------------------|----------|
| P1     | Ø0-60mm            | ±0.015mm |
| P2     | Ø0-160mm           | ±0.02mm  |
| P3     | Ø0-250mm           | ±0.03mm  |
| P4     | Ø3.2-80mm          | ±0.015mm |
| P5     | Ø3.2-180mm         | ±0.02mm  |
| P6     | Ø3.2-280mm         | ±0.03mm  |
| P7     | Ø0-2.8mm           | ±0.015mm |



EDGE FINDERS



6562-3 6562-4

- ▶ Hardened shank and contact point
- ▶ Suitable for machine speed 400-600rpm

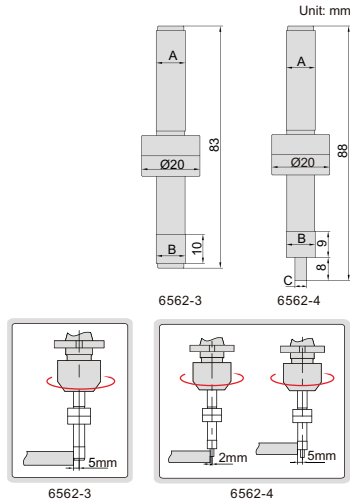

| Code   | Shank (A) | Contact point (B) | Contact point (C) | Accuracy | List Price (₹) | Promotion Price (₹) |
|--------|-----------|-------------------|-------------------|----------|----------------|---------------------|
| 6562-3 | Ø10mm     | Ø10mm             | —                 | 5µm      | 1701           | 1529                |
| 6562-4 | Ø10mm     | Ø10mm             | Ø4mm              | 5µm      | 1745           | 1568                |

ELECTRONIC EDGE FINDER

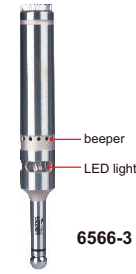
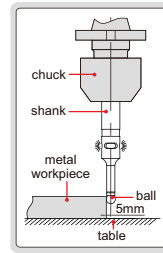

6566-3

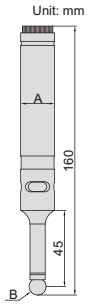

- ▶ The shank is electrically conducted to the metal workpiece through the chuck and table, the LED lights up and the beeper sounds, when the ball touches the workpiece
- ▶ Not suitable for rotary use
- ▶ Hardened shank and contact ball
- ▶ Battery: 23AE, 12Vx1pc

| Code   | Shank (A) | Contact ball (B) | Accuracy | Beeper | List Price (₹) | Promotion Price (₹) |
|--------|-----------|------------------|----------|--------|----------------|---------------------|
| 6566-3 | Ø20mm     | SØ10mm           | 5µm      | with   | 5880           | 5364                |

ZERO SETTER

- ▶ Magnetic base



2397-502A

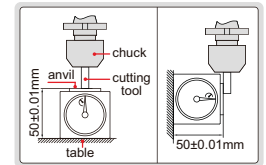
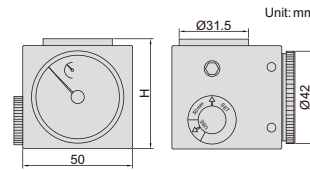

| Code      | Height (H) | Accuracy | Test force   | List Price (₹) | Promotion Price (₹) |
|-----------|------------|----------|--------------|----------------|---------------------|
| 2397-502A | 50mm       | ±10µm    | 9N (at 50mm) | 12303          | 9469                |

DATA TRANSFER SYSTEM

- ▶ Transfer distance is 10 meter

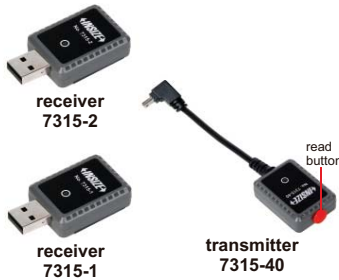

7315-2 application (multichannel)

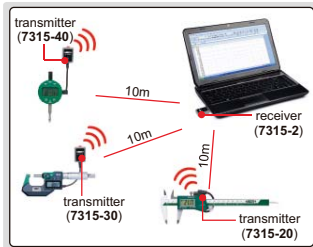

7315-1 application (single channel)

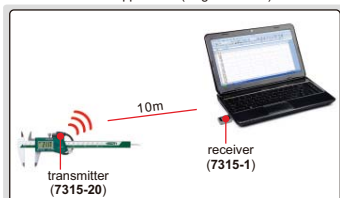

| Code    | Description             | Plug to product | Remark  | List Price (₹) | Promotion Price (₹) |
|---------|-------------------------|-----------------|---|----------------|---------------------|
| 7315-2  | multichannel receiver   |                 | Connected with maximum 8 transmitters, each transmitter has ID code, text format virtual com port, converted to keyboard format (same as keyboard typewrite input into EXCEL, WORD etc.) with supplied software | 17938          | 15247               |
| 7315-1  | single channel receiver |                 | Connected with 1 transmitter only, can change the transmitter, keyboard format (same as keyboard typewrite input into EXCEL, WORD etc., without software)   | 5938           | 5047                |
| 7315-20 | transmitter             |                 | for digital calipers<br>for 1156 series digital height gages  | 4460           | 3791                |
| 7315-30 | transmitter             |                 | for digital depth gages<br>for digital micrometers<br>for digital three points internal micrometers   | 4460           | 3791                |
| 7315-40 | transmitter             |                 | for digital indicators  | 4460           | 3791                |

**PROFILE PROJECTOR**  
CODE ISP-Z3015



Screen diameter: 300mm

X-Y travel: 150x50mm

**SPECIFICATION**

|                            |                        |   |                |                |                 |
|----------------------------|------------------------|---|----------------|----------------|-----------------|
| <b>List Price (₹)</b>      |                        | 539156  |                |                |                 |
| <b>Promotion Price (₹)</b> |                        | 406762  |                |                |                 |
| Lens                       | magnification          | 10X (included)  | 20X (optional) | 50X (optional) | 100X (optional) |
|                            | view field             | Ø30mm   | Ø15mm          | Ø6mm           | Ø3mm            |
|                            | working distance       | 77.7mm  | 44.3mm         | 38.4mm         | 25.3mm          |
| Max. workpiece height      |                        | 90mm  | 90mm           | 90mm           | 90mm            |
| Magnification accuracy     |                        | ±0.08%  |                |                |                 |
| Image                      |                        | erect image   |                |                |                 |
| Projector screen           |                        | diameter: Ø300mm  |                |                |                 |
|                            |                        | rotation range: 0°~360°, resolution: 1" or 0.01°                      |                |                |                 |
|                            |                        | reference lines: cross-hairs  |                |                |                 |
| Stage                      | metal stage size       | 340×152mm   |                |                |                 |
|                            | glass stage size       | 196×96mm  |                |                |                 |
|                            | X-Y stage travel       | range: 150×50mm   |                |                |                 |
|                            |                        | resolution: 0.5µm   |                |                |                 |
|                            | Z (focus) travel range | 90mm  |                |                |                 |
| max. load capacity         | 4kg                    |   |                |                |                 |
| Illumination               |                        | contour illumination: 24V/150W halogen lamp, brightness is adjustable |                |                |                 |
|                            |                        | surface illumination: 24V/150W halogen lamp                           |                |                |                 |
| Data processing unit       | display                | X-Y stage travel, screen rotation                                     |                |                |                 |
|                            | output                 | RS232C  |                |                |                 |
| Data processing unit       | function               | measure coordinate of point   |                |                |                 |
|                            |                        | measure coordinate of line  |                |                |                 |
|                            |                        | measure center coordinate, radius of circle with three points         |                |                |                 |
|                            |                        | measure distance between two objects                                  |                |                |                 |
|                            |                        | measure angle with four points or two lines                           |                |                |                 |
|                            |                        | set origin of coordinate  |                |                |                 |
|                            |                        | coordinate transform  |                |                |                 |
|                            |                        | set midpoint of coordinate  |                |                |                 |
| Power supply               |                        | 110/220V, 50/60Hz   |                |                |                 |
| Dimension (L×W×H)          |                        | 550×770×1100mm  |                |                |                 |
| Weight                     |                        | 135kg   |                |                |                 |

**OPTIONAL ACCESSORY**

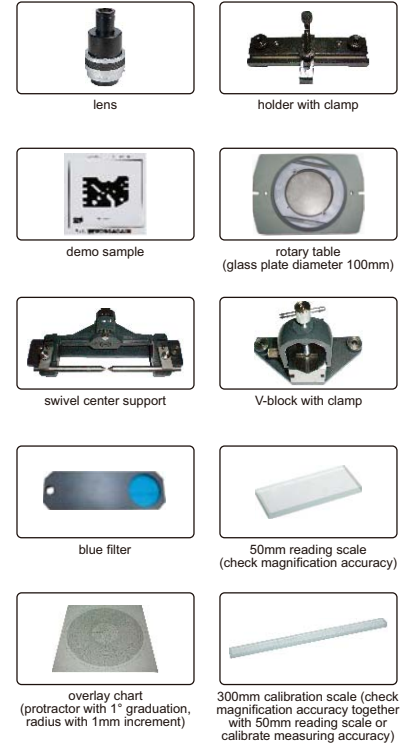

**STANDARD DELIVERY**

|   |       |
|---|-------|
| Main unit   | 1 pc  |
| 10X lens with half-reflection mirror and oblique illuminator mirror | 1 pc  |
| Overlay chart clip  | 4 pcs |
| Foot-switch   | 1 pc  |
| Anti-dust cover   | 1 pc  |

**OPTIONAL ACCESSORY**

|   |                    |
|---|--------------------|
| 20X lens with half-reflection mirror and oblique illuminator mirror | ISP-Z3015-LENS20X  |
| 50X lens with half-reflection mirror                                | ISP-Z3015-LENS50X  |
| 100X lens with half-reflection mirror                               | ISP-Z3015-LENS100X |
| Rotary table  | ISP-Z3015-TABLE    |
| Overlay chart   | ISP-Z3015-CHART    |
| Holder with clamp   | ISP-Z3015-HOLDER   |
| Swivel center support   | ISP-Z3015-SUPPORT  |
| V-block with clamp  | ISP-Z3015-VBLOCK   |
| 50mm reading scale  | ISP-Z3015-SCALE50  |
| 300mm calibration scale   | ISP-Z3015-RULE     |
| Blue filter   | ISP-Z3015-FILTER   |
| Demo sample   | ISP-Z3015-DEMO     |

## VISION MEASURING SYSTEM



### SPECIFICATION

| Code                      | ISD-V150   | ISD-V250      | ISD-V300      |
|---------------------------|--|---------------|---------------|
| List Price (₹)            | 406623   | 458484        | 505451        |
| Promotion Price (₹)       | 345264   | 397555        | 441272        |
| Measuring range (X×Y×Z)   | 150×100×200mm                                    | 250×150×200mm | 300×200×200mm |
| Stage size                | 354×228mm  | 450×280mm     | 500×330mm     |
| Glass stage size          | 210×160mm  | 306×196mm     | 350×250mm     |
| Resolution of X/Y/Z axis  | 0.5µm  |               |               |
| Accuracy of X/Y axis      | ≤(2.5+L/100)µm (L is the measuring length in mm) |               |               |
| Repeatability of X/Y axis | 2µm  |               |               |
| Objective                 | 0.7X~4.5X (zoom)                                 |               |               |
| Working distance          | 92mm   |               |               |
| Magnification             | 33X~195X (on 19" monitor)                        |               |               |
| Camera                    | 1/3" color CCD, 0.3M pixel                       |               |               |
| Illumination              | surface and contour with adjustable LED          |               |               |
| Max. height of workpiece  | 160mm  |               |               |
| Max. weight of workpiece  | 20kg   |               |               |
| Operation system          | Windows 7/8/10                                   |               |               |
| Drive method              | manual   |               |               |
| Power supply              | 110/220V, 50/60Hz                                |               |               |
| Dimension (L×W×H)         | 560×540×850mm                                    | 760×600×900mm | 760×600×900mm |
| Weight                    | 100kg  | 120kg         | 140kg         |

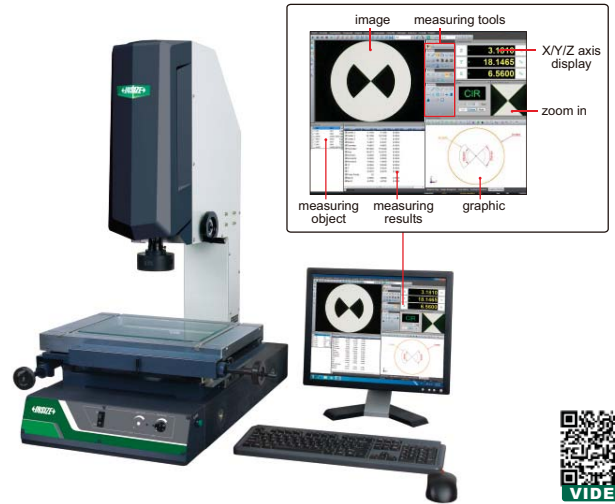

ISD-V250

computer is not included

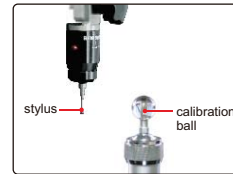

probe (optional), includes Ø2mm and Ø3mm styli, Ø25mm calibration ball, measuring accuracy is 10µm



lens with coaxial light (optional, must be installed in factory)



software CD (included)

### STANDARD DELIVERY

|                         |      |
|-------------------------|------|
| Main unit               | 1 pc |
| Video card with dongle  | 1 pc |
| Software disc           | 1 pc |
| Calibration glass chart | 1 pc |
| Laser positioner        | 1 pc |
| Clay                    | 1 pc |
| Foot switch             | 1 pc |
| Anti-dust cover         | 1 pc |

### OPTIONAL ACCESSORY

|                                       |   |
|---------------------------------------|---|
| 0.5X auxiliary objective              | Code: <b>ISD-V-OB05X</b><br>Working distance: 175mm<br>Magnification: 16.5~97.5X (on 19" monitor) |
| 2X auxiliary objective                | Code: <b>ISD-V-OB2X</b><br>Working distance: 36mm<br>Magnification: 66~390X (on 19" monitor)      |
| Probe                                 | Code: <b>ISD-V-PROBE</b><br>Includes Ø2mm and Ø3mm styli, Ø25mm calibration ball                  |
| Lens with coaxial light               | Code: <b>ISD-V-LENS</b> (must be installed in factory)  |
| Vision measuring system with computer | Code: <b>ISD-V150A, ISD-V250A, ISD-V300A</b>  |

### SOFTWARE

- Operation system: Windows 7/8/10
- Language: English
- Single measuring tools:

- measure coordinate of point
- measure center coordinate and axis length of ellipse
- measure length of open curve
- measure distance of two elements

- measure center coordinate, diameter and area of circle
- measure length, width and area of rectangle
- measure length and area of closed curve

- measure distance between two points
- measure length, width and diameter of key slot
- measure angle of two lines

- measure length and diameter of arc
- measure width and diameter of ring
- measure focus distance of surface

### Combined measuring tools:

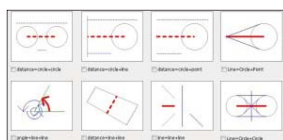

measure distance and angle of two elements

### Focus indicator:

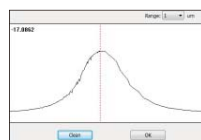

### Coordinate transfer:

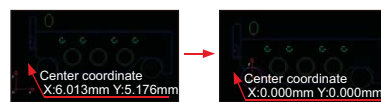

### Data export to CAD, EXCEL and WORD

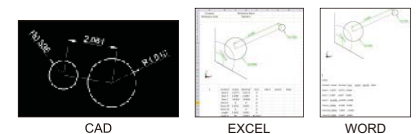

### Profile detection:



### Edge-detection:



### Contour scanning:

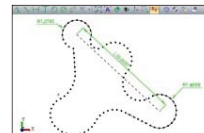

### CAD measuring:

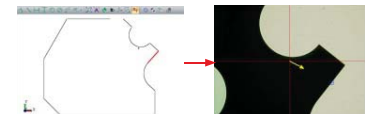

Input CAD drawing and set reference, move the stage to make the target box in the center of crosshair, then the software will do automatic measurement

## DIGITAL MEASURING MICROSCOPE (WITH DISPLAY)

TAKE PICTURES

MEASUREMENT

BUILT-IN SOFTWARE WITHOUT COMPUTER

- ▶ 1080P high-definition image
- ▶ Built-in software without computer, operation by mouse
- ▶ Take pictures, saved to USB flash disk
- ▶ Measurement results can be output to Excel
- ▶ Automatic white balance and exposure
- ▶ Brightness, contrast ratio, gain are adjustable

### SPECIFICATION

|                     |  |
|---------------------|--|
| Code                | <b>ISM-DL301*</b><br>(with contour illumination) |
| List Price (₹)      | 144468   |
| Promotion Price (₹) | <b>133171</b>                                    |
| Magnification       | 15X~100X   |
| Sensor              | 1/2" CMOS  |
| Pixel               | 2M   |
| Resolution          | 1920×1080  |
| Frame rate          | 60fps  |
| Output              | HDMI   |
| Power supply        | power adapter and 220V, 50/60Hz*                 |
| Dimension (L×W×H)   | 570×300×430mm                                    |
| Weight              | 6.5kg  |

\*Add "-U" on code No. when power supply is 110V, 50/60Hz

### STANDARD DELIVERY

|                        |       |
|------------------------|-------|
| Main unit              | 1 pc  |
| 0.5X camera adapter    | 1 pc  |
| 1X auxiliary objective | 1 pc  |
| Calibration plate      | 1 pc  |
| 16G USB flash disk     | 1 pc  |
| White/black plate      | 1 pc  |
| Mouse                  | 1 pc  |
| HDMI cable             | 1 pc  |
| Power adapter          | 2 pcs |

### OPTIONAL ACCESSORY

|                                   |                     |
|-----------------------------------|---------------------|
| 1X camera adapter                 | <b>ISM-DL-CA1X</b>  |
| 2X auxiliary objective            | <b>ISM-DL-OB2X</b>  |
| X-Y glass stage (travel: 74×60mm) | <b>ISM-DL-STAGE</b> |



ISM-DL301 (with contour illumination)

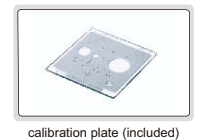
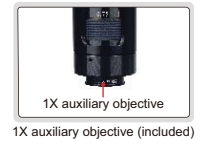

### MEASURING ACCURACY

| Magnification | Measuring accuracy |
|---------------|--------------------|
| 15X           | ±8μm               |
| 30X           | ±6μm               |
| 50X           | ±6μm               |
| 80X           | ±4μm               |
| 100X          | ±4μm               |
| >100X         | ±4μm               |

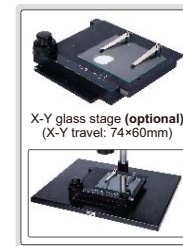

### MAGNIFICATION, FOCUS DISTANCE AND VIEW FIELD

| Auxiliary Objective | Specification  | Camera adapter    |                   |
|---------------------|----------------|-------------------|-------------------|
|                     |                | 0.5X (included)   | 1X (optional)     |
| 1X (included)       | Magnification  | 15~100X           | 30~200X           |
|                     | Focus distance | 70±2mm            | 70±2mm            |
|                     | View field     | 16×11~2.5×1.6mm   | 7.8×5.3~1.2×0.8mm |
| 2X (optional)       | Magnification  | 30~200X           | 60~400X           |
|                     | Focus distance | 29±2mm            | 29±2mm            |
|                     | View field     | 7.8×5.3~1.2×0.8mm | 3.8×2.7~0.6×0.4mm |

### SOFTWARE

- ▶ Language: English
- ▶ Output to Excel
- ▶ Edge-detection:

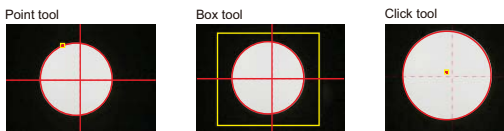

### Measurement tools:

- |  |  |   |   |
|--|--|---|---|
| measure length of line or distance between two points                | measure distance between multiple parallel lines                   | measure length of line or distance between two points in vertical direction   | measure distance between two parallel lines   |
| measure angle from horizontal line                                   | measure angle from vertical line                                   | measure length of line or distance between two points in horizontal direction | measure distance between point and line       |
| measure radius, diameter, girth and area of circle with three points | measure radius, diameter, girth and area concentric of circles     | measure girth and area of polygon   | measure distance between three parallel lines |
| measure minimum distance between point and circle                    | measure distance between point and center of circle                | measure length, width, girth and area of rectangle                            | measure radius, length and angle of arc       |
| measure minimum distance between line and circle                     | measure distance between line and center of circle                 | measure maximum distance between point and circle                             | measure angle of two lines                    |
| measure minimum distance between two circles                         | measure center distance between two circles                        | measure maximum distance between line and circle                              | cross hair                                    |
| add text   | measure radius, diameter, girth and area of circle with two points | measure maximum distance between two circles                                  |   |

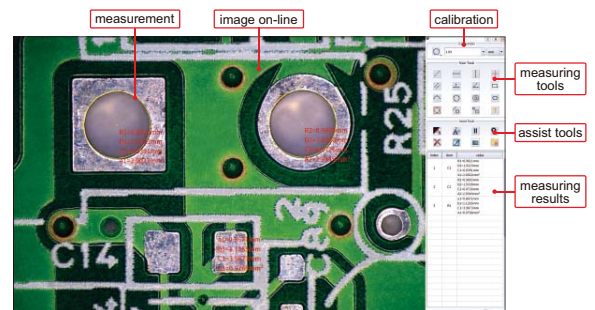

### DIGITAL MICROSCOPE WITH DISPLAY (ECONOMIC MODEL)

- ▶ 1080P high-definition image
- ▶ Take pictures and videos, saved to memory card
- ▶ Automatic exposure and white balance
- ▶ Brightness, contrast ratio, gain are adjustable
- ▶ Display cross hair (blue/green/red/yellow/black/brown colors)

**SPECIFICATION**

|                            |                   |
|----------------------------|-------------------|
| <b>Code</b>                | <b>5304-DL100</b> |
| <b>List Price (₹)</b>      | 64862             |
| <b>Promotion Price (₹)</b> | <b>59859</b>      |
| <b>Magnification</b>       | 28X~91X           |
| <b>Focus distance</b>      | 28~78mm           |
| <b>View field</b>          | 13×7mm~3×2mm      |
| <b>Sensor</b>              | 1/2.8" CMOS       |
| <b>Pixel</b>               | 2M                |
| <b>Resolution</b>          | 1920×1080         |
| <b>Frame rate</b>          | 60fps             |
| <b>Output</b>              | HDMI              |
| <b>Power supply</b>        | power adapter     |
| <b>Dimension (L×W×H)</b>   | 380×260×500mm     |
| <b>Weight</b>              | 4kg               |

TAKE PICTURES AND VIDEOS



8G memory card and holder (included)

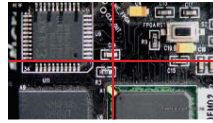

display cross hair (blue/green/red/yellow/black/brown colors)

**STANDARD DELIVERY**

|                           |       |
|---------------------------|-------|
| Main unit                 | 1 pc  |
| 8G memory card and holder | 1 pc  |
| Mouse                     | 1 pc  |
| White/black plate         | 1 pc  |
| Power adapter             | 2 pcs |

**OPTIONAL ACCESSORY**

X-Y glass stage (travel: 74×60mm) ISM-DL-STAGE

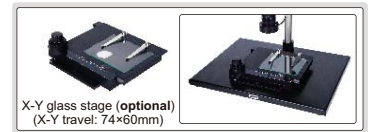

### DIGITAL AUTO FOCUS MICROSCOPE (WITH DISPLAY)

- ▶ 1080P high-definition image
- ▶ Auto focus camera
- ▶ Take pictures and videos, saved to memory card
- ▶ Automatic exposure and white balance
- ▶ Brightness, contrast ratio, gain are adjustable
- ▶ Display cross hair (blue/green/red/yellow/black/brown colors)

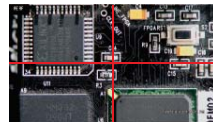

display cross hair (blue/green/red/yellow/black/brown colors)

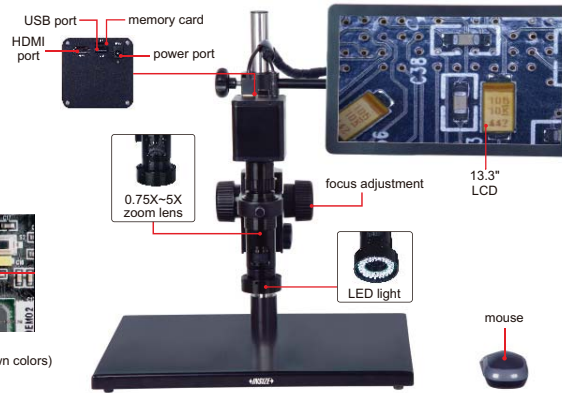

AUTO FOCUS

TAKE PICTURES AND VIDEOS



**SPECIFICATION**

|                            |                   |
|----------------------------|-------------------|
| <b>Code</b>                | <b>5303-AF103</b> |
| <b>List Price (₹)</b>      | 138876            |
| <b>Promotion Price (₹)</b> | <b>128163</b>     |
| <b>Magnification</b>       | 20X~123X          |
| <b>Sensor</b>              | 1/2.8" CMOS       |
| <b>Pixel</b>               | 2M                |
| <b>Resolution</b>          | 1920×1080         |
| <b>Frame rate</b>          | 60fps             |
| <b>Output</b>              | HDMI              |
| <b>Power supply</b>        | power adapter     |
| <b>Dimension (L×W×H)</b>   | 570×300×430mm     |
| <b>Weight</b>              | 6.5kg             |

**OPTIONAL ACCESSORY**

|                                   |                |
|-----------------------------------|----------------|
| 1X camera adapter                 | ISM-DL-CA1X    |
| 2X auxiliary objective            | ISM-DL-OB2X    |
| X-Y glass stage (travel: 74×60mm) | ISM-DL-STAGE   |
| X-Y metal stage                   | ISM-DL-STAGE1  |
| LED auxiliary lighting            | ISM-DL-LED     |
| Lens with coaxial light           | ISM-DL-COAXIAL |
| Auxiliary objective lens          |                |

**STANDARD DELIVERY**

|                           |      |
|---------------------------|------|
| Main unit                 | 1 pc |
| 0.5X camera adapter       | 1 pc |
| 1X auxiliary objective    | 1 pc |
| 8G memory card and holder | 1 pc |

|                   |       |
|-------------------|-------|
| White/black plate | 1 pc  |
| Mouse             | 1 pc  |
| HDMI cable        | 1 pc  |
| Power adapter     | 2 pcs |

**MAGNIFICATION, FOCUS DISTANCE AND VIEW FIELD**

| Auxiliary Objective | Specification  | Camera adapter    |                   |
|---------------------|----------------|-------------------|-------------------|
|                     |                | 0.5X (included)   | 1X (optional)     |
| 1X (included)       | Magnification  | 20~123X           | 40~246X           |
|                     | Focus distance | 48~84mm           | 48~84mm           |
|                     | View field     | 13×7~2.2×1mm      | 6.3×3.5~1.1×0.5mm |
| 2X (optional)       | Magnification  | 40~246X           | 80~492X           |
|                     | Focus distance | 24~42mm           | 24~42mm           |
|                     | View field     | 6.5×3.5~1.1×0.5mm | 3.3×1.8~0.6×0.3mm |

**AUTO FOCUS DISTANCE**

| Zoom objective scale | 0.75X   | 1X      | 1.5X    | 2X      | 2.5X    |
|----------------------|---------|---------|---------|---------|---------|
| Auto focus distance  | 48~84mm | 50~78mm | 55~73mm | 62~71mm | 65~70mm |
| Zoom objective scale | 3X      | 3.5X    | 4X      | 4.5X    | 5X      |
| Auto focus distance  | 66~70mm | 67~70mm | 68~70mm | 68~70mm | 68~70mm |

## DIGITAL AUTO FOCUS MICROSCOPE CODE 5302-AF105

AUTO FOCUS

TAKE PICTURES AND VIDEOS

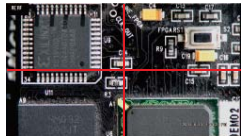

display cross hair  
(blue/green/red/yellow/black/brown colors)

- ▶ 1080P high-definition image
- ▶ Auto focus camera
- ▶ Take pictures and videos, saved to memory card
- ▶ Connected to TV by HDMI port
- ▶ Automatic exposure and white balance
- ▶ Brightness, contrast ratio, gain are adjustable
- ▶ Display cross hair (blue/green/red/yellow/black/brown colors)

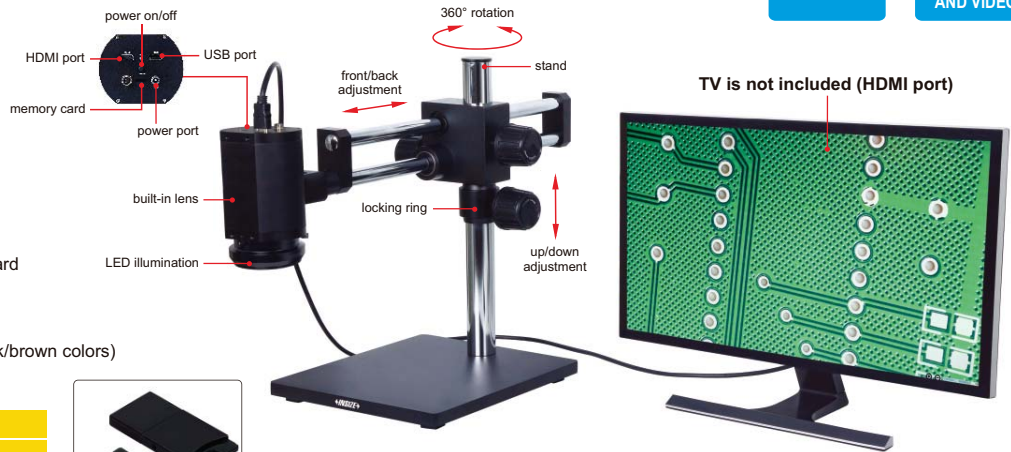

TV is not included (HDMI port)

### SPECIFICATION

|                     |                        |
|---------------------|------------------------|
| List Price (₹)      | 134542                 |
| Promotion Price (₹) | 121087                 |
| Magnification       | 1.8X~27.5X (on 28" TV) |
| Sensor              | 1/2.8" CMOS            |
| Pixel               | 2M                     |
| Resolution          | 1920×1080              |
| Frame rate          | 60fps                  |
| Auto Focus distance | 100mm~∞                |
| Output              | HDMI                   |
| Power supply        | power adapter          |
| Dimension (L×W×H)   | 500×280×410mm          |
| Weight              | 17kg                   |



8G memory card and holder  
(included)

### STANDARD DELIVERY

|                           |       |
|---------------------------|-------|
| Main unit (with stand)    | 1 pc  |
| LED illumination          | 1 pc  |
| 8G memory card and holder | 1 pc  |
| Mouse                     | 1 pc  |
| HDMI cable (for TV)       | 1 pc  |
| Power adapter             | 2 pcs |

### FOCUS DISTANCE, MAGNIFICATION AND VIEW FIELD (MANUAL FOCUS)

| Focus distance (mm) | Magnification (on 28" TV) | View field (mm) |
|---------------------|---------------------------|-----------------|
| 100mm               | 4.5~27.5X                 | 24×14~161×90mm  |
| 150mm               | 3~21X                     | 30×17~240×128mm |
| 200mm               | 2.3~17.5X                 | 38×20~305×176mm |
| 250mm               | 2~15X                     | 42×24~320×210mm |
| 270mm               | 1.8~14.4X                 | 43×25~378×240mm |

## DIGITAL MEASURING MICROSCOPE



software CD (included)

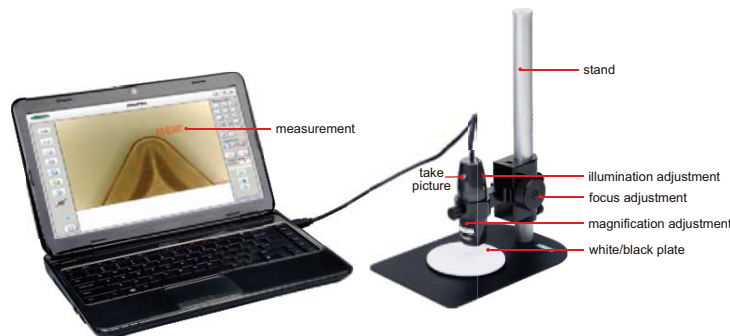

ISM-PM200SA  
computer is not included



focus support  
(included)

put the digital microscope  
directly on the workpiece for  
inspection and measurement

- ▶ Can take pictures and videos
- ▶ Supplied with software

### SPECIFICATION

|                     |  |
|---------------------|--|
| Code                | ISM-PM200SA                              |
| List Price (₹)      | 18265                                    |
| Promotion Price (₹) | 13203                                    |
| Magnification       | 10X~200X                                 |
| Focus distance      | short focus distance                     |
| Stand               | standard                                 |
| Focus support       | included                                 |
| Calibration rule    | graduation 0.1 and 1mm                   |
| Pixel               | 2M (resolution: 1600×1200)               |
| Illumination        | built-in adjustable LED                  |
| Power supply        | USB 2.0 cable (voltage required: 5±0.1V) |

### MAGNIFICATION, FOCUS DISTANCE, VIEW FIELD AND ACCURACY

| ISM-PM200SA   |                |                 |          |
|---------------|----------------|-----------------|----------|
| Magnification | Focus distance | View field (mm) | Accuracy |
| 50X           | 21mm           | 8.1×6.4         | 30µm     |
| 100X          | 13mm           | 3.9×3.1         | 15µm     |
| 150X          | 16mm           | 2.6×2.1         | 10µm     |
| 200X          | 19mm           | 1.8×1.5         | 8µm      |

### OPTIONAL ACCESSORY

|               |               |
|---------------|---------------|
| Green filter  | ISM-PM-GREEN  |
| Yellow filter | ISM-PM-YELLOW |
| Blue filter   | ISM-PM-BLUE   |



filter (optional)

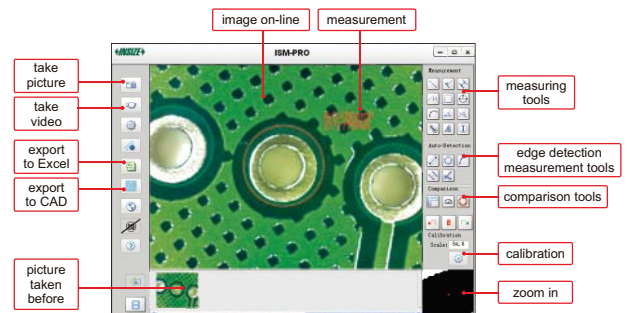

**ZOOM STEREO MICROSCOPE**  
CODE ISM-ZS50

**SPECIFICATION**

|                               |  |
|-------------------------------|--|
| List Price (₹)                | 71173  |
| Promotion Price (₹)           | 55008  |
| Optical tube                  | binocular                                      |
| Eyepiece (wide field)         | 10X (view field: Ø22mm)                        |
| Objective                     | 0.8X-5X (zoom)                                 |
| Zoom ratio                    | 1:6.3  |
| Pupil distance                | 55-75mm (adjustable)                           |
| Diopter adjustment            | ±5 diopter (two eyepieces)                     |
| Working distance of objective | 115mm  |
| Max. workpiece height         | 215mm  |
| Illumination                  | adjustable reflected and transmitted LED light |
| Power supply                  | 110/220V, 50/60Hz                              |
| Dimension (L×W×H)             | 290x260x480mm                                  |
| Weight                        | 4.9kg  |

**STANDARD DELIVERY**

|                          |       |
|--------------------------|-------|
| Main unit                | 1 pc  |
| WF10X eyepiece           | 2 pcs |
| Ø100mm glass plate       | 1 pc  |
| Ø100mm white/black plate | 1 pc  |
| Anti-dust cover          | 1 pc  |



**OPTIONAL ACCESSORY**

|                     |   |                 |
|---------------------|---|-----------------|
| Auxiliary objective | 0.5X  | ISM-ZS50-OB05X  |
|                     | 2X  | ISM-ZS50-OB2X   |
| Eyepiece            | 10X dividing eyepiece (graduation 0.1mm/div.) | ISM-ZS50-EPD10X |
|                     | WF15X (view field: Ø16mm)                     | ISM-ZS50-EP15X  |
|                     | WF20X (view field: Ø12mm)                     | ISM-ZS50-EP20X  |
| Digital camera      |   | ISM-D500        |
| LED ring light      |   | ISM-ZS-RL       |

**ZOOM STEREO MICROSCOPE**  
CODE ISM-ZS30

**SPECIFICATION**

|                               |  |
|-------------------------------|--|
| List Price (₹)                | 34466  |
| Promotion Price (₹)           | 26638  |
| Optical tube                  | binocular                                      |
| Eyepiece (wide field)         | 10X (view field: Ø20mm)                        |
| Objective                     | 1X-4.5X (zoom)                                 |
| Zoom ratio                    | 1:4.5  |
| Pupil distance                | 55-75mm (adjustable)                           |
| Diopter adjustment            | ±5 diopter (two eyepieces)                     |
| Working distance of objective | 97mm   |
| Max. workpiece height         | 147mm  |
| Illumination                  | adjustable reflected and transmitted LED light |
| Power supply                  | 110/220V, 50/60Hz                              |
| Dimension (L×W×H)             | 260×190×400mm                                  |
| Weight                        | 4.3kg  |

**STANDARD DELIVERY**

|                         |       |
|-------------------------|-------|
| Main unit               | 1 pc  |
| WF 10X eyepiece         | 2 pcs |
| Ø95mm glass plate       | 1 pc  |
| Ø95mm white/black plate | 1 pc  |
| Anti-dust cover         | 1 pc  |

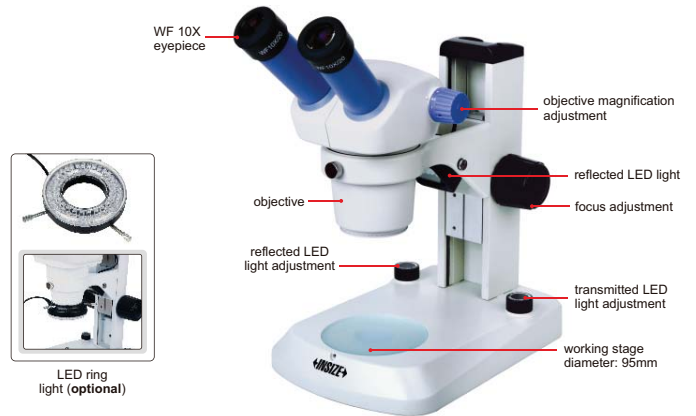

**OPTIONAL ACCESSORY**

|                     |   |                 |
|---------------------|---|-----------------|
| Auxiliary objective | 0.5X  | ISM-ZS30-OB05X  |
|                     | 0.63X   | ISM-ZS30-OB06X  |
|                     | 0.75X   | ISM-ZS30-OB07X  |
|                     | 2X  | ISM-ZS30-OB2X   |
| Eyepiece            | 10X dividing eyepiece (graduation 0.1mm/div.) | ISM-ZS30-EPD10X |
|                     | WF15X (view field: Ø16mm)                     | ISM-ZS50-EP15X  |
|                     | WF20X (view field: Ø12mm)                     | ISM-ZS50-EP20X  |
| Digital camera      |   | ISM-D500        |
| LED ring light      |   | ISM-ZS-RL       |

**FOLDING MAGNIFIER**

► Glass lens

| Code   | Magnification | Lens diameter (ØD) | List Price (₹) | Promotion Price (₹) |
|--------|---------------|--------------------|----------------|---------------------|
| 7511-8 | 8X            | Ø21mm              | 145            | 122                 |

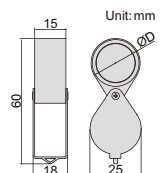

7511-8

**FOLDING MAGNIFIER WITH ILLUMINATION**

- ▶ Glass lens
- ▶ Powered by 3xLR927 batteries (included)



7515-10

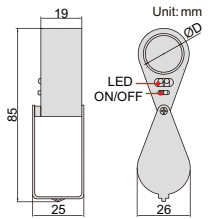

| Code    | Magnification | Lens diameter (ØD) | List Price (₹) | Promotion Price (₹) |
|---------|---------------|--------------------|----------------|---------------------|
| 7515-10 | 10X           | Ø21mm              | 399            | 333                 |

**THREE WAYS MAGNIFIER WITH ILLUMINATION**

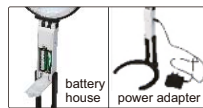

- ▶ Plastic lens
- ▶ Powered by 2xAAA batteries (included) or power adapter (110~240V, 50~60Hz)



7512-1

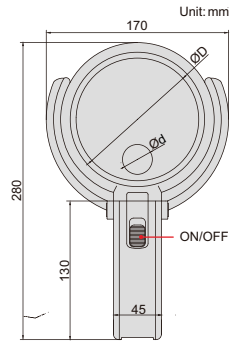

| Code   | Magnification | Lens diameter (ØD) | Lens diameter (ØD) | List Price (₹) | Promotion Price (₹) |
|--------|---------------|--------------------|--------------------|----------------|---------------------|
| 7512-1 | 2X/4X         | Ø120mm             | Ø28mm              | 1075           | 898                 |

**MAGNIFIERS WITH ILLUMINATION**

- ▶ Glass lens
- ▶ Powered by 3xAAA batteries (included)



7513-2

7513-4

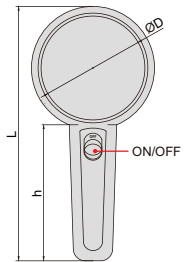

| Code   | Magnification | Lens diameter (ØD) | L     | H    | List Price (₹) | Promotion Price (₹) |
|--------|---------------|--------------------|-------|------|----------------|---------------------|
| 7513-2 | 2X            | Ø75mm              | 170mm | 90mm | 363            | 303                 |
| 7513-4 | 4X            | Ø50mm              | 145mm | 90mm | 333            | 278                 |

**MAGNIFIER WITH ILLUMINATION**

- ▶ Two magnifications
- ▶ LED illumination
- ▶ Powered by 2pcs AAA batteries (included)
- ▶ Resin lens



7518-26

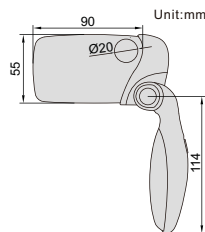

| Code    | Magnification | Lens size | List Price (₹) | Promotion Price (₹) |
|---------|---------------|-----------|----------------|---------------------|
| 7518-26 | 2X/6X         | 90x55mm   | 674            | 556                 |

**FOLDING MAGNIFIER WITH ILLUMINATION**

- ▶ Plastic lens
- ▶ Powered by 2xCR1620 batteries (included)
- ▶ LED lights up automatically when  $\alpha$  is over 130°

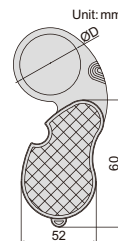

7514-1

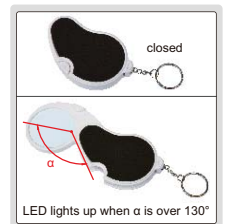

| Code   | Magnification | Lens diameter (ØD) | List Price (₹) | Promotion Price (₹) |
|--------|---------------|--------------------|----------------|---------------------|
| 7514-1 | 2.5X          | Ø45mm              | 315            | 263                 |



**TABLE MAGNIFIER WITH ILLUMINATION  
CODE 7516-5D**



- ▶ LED illumination, working life 20000h

**SPECIFICATION**

|                     |                               |
|---------------------|-------------------------------|
| List Price (₹)      | 3770                          |
| Promotion Price (₹) | 3246                          |
| Magnification       | 2.25X                         |
| Diopter             | 5D                            |
| Lens diameter       | Ø122mm                        |
| Illumination        | power: 7W, illuminance: 420lm |
| Power supply        | 100~240V, 50~60Hz             |

**TELESCOPING MAGNETIC PICK-UP**

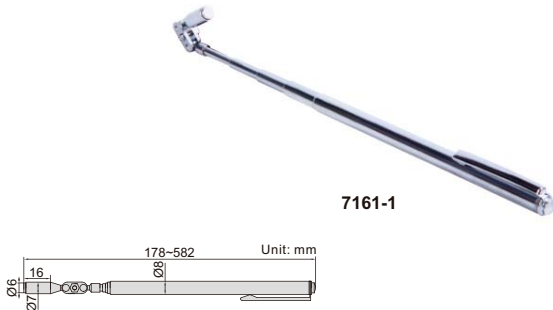

- ▶ Pick up metal parts from hidden areas
- ▶ Rotation of the magnetic head: 360°
- ▶ Length of the handle is adjustable, the handle is made of brass and chrome plated

| Code   | Size of magnetic tip | Magnetic force | Length    | List Price (₹) | Promotion Price (₹) |
|--------|----------------------|----------------|-----------|----------------|---------------------|
| 7161-1 | Ø6mm                 | 0.45kgf        | 178~582mm | 513            | 462                 |

**TABLE MAGNIFIER WITH ILLUMINATION  
CODE 7517-3D**

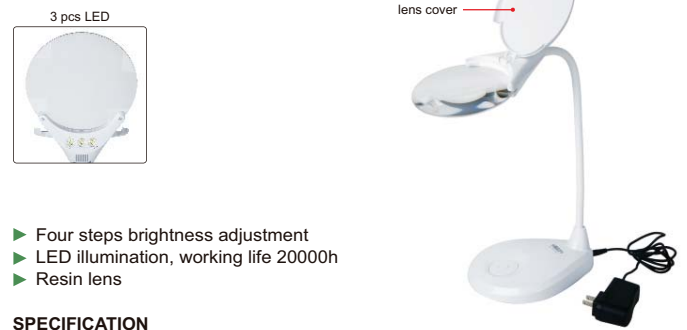

- ▶ Four steps brightness adjustment
- ▶ LED illumination, working life 20000h
- ▶ Resin lens

**SPECIFICATION**

|                     |                               |
|---------------------|-------------------------------|
| List Price (₹)      | 3392                          |
| Promotion Price (₹) | 2801                          |
| Magnification       | 1.75X                         |
| Diopter             | 3D                            |
| Lens diameter       | Ø125mm                        |
| Illumination        | power: 3W, illuminance: 260lm |
| Power supply        | 100~240V, 50~60Hz             |

**TELESCOPING INSPECTION MIRRORS**

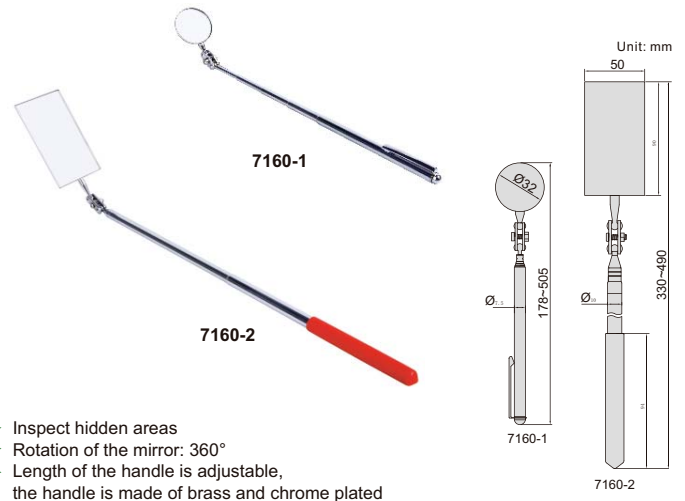

- ▶ Inspect hidden areas
- ▶ Rotation of the mirror: 360°
- ▶ Length of the handle is adjustable, the handle is made of brass and chrome plated

| Code   | Size of mirror | Length    | List Price (₹) | Promotion Price (₹) |
|--------|----------------|-----------|----------------|---------------------|
| 7160-1 | Ø32mm          | 178~505mm | 477            | 427                 |
| 7160-2 | 50x90mm        | 330~490mm | 1140           | 1030                |

**TELESCOPING INSPECTION MIRROR  
(WITH ILLUMINATION)**



- ▶ Inspect hidden areas
- ▶ The head can bend and rotate
- ▶ Telescoping handle, made of stainless steel
- ▶ With two CR2032 batteries

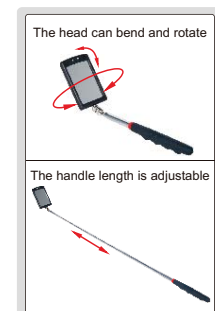

| Code   | Size of mirror | Length    | List Price (₹) | Promotion Price (₹) |
|--------|----------------|-----------|----------------|---------------------|
| 7162-1 | 65x42mm        | 285~875mm | 411            | 340                 |

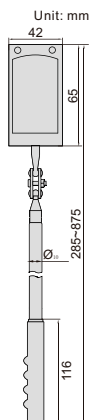

## TELESCOPING MAGNETIC PICK-UP AND FLASHLIGHT

- ▶ For illumination and pick up metal parts in hidden areas
- ▶ The head can bend
- ▶ Telescoping handle, made of stainless steel
- ▶ Magnetic head and end
- ▶ With four LR44 batteries



7163-1

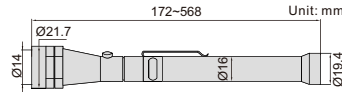

| Code   | Magnetic end | Magnetic head | Flashlight range | Battery life | Length    | List Price (₹) | Promotion Price (₹) |
|--------|--------------|---------------|------------------|--------------|-----------|----------------|---------------------|
| 7163-1 | 4kgf         | 2kgf          | 3m               | 8h           | 172-568mm | 553            | 457                 |



## ROUGHNESS TESTER CODE ISR-C100

ATTENTION: PROBE IS NOT EXTENDABLE

DATA OUTPUT

- ▶ 16 roughness parameters
- ▶ With probe position indicator
- ▶ Connected with printer via bluetooth
- ▶ Can display roughness values, profile and curve
- ▶ Memory of maximum 100 results
- ▶ Automatic power off



software CD (included)



remote control (included)

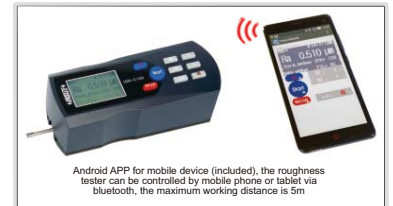

measuring software for PC (included)

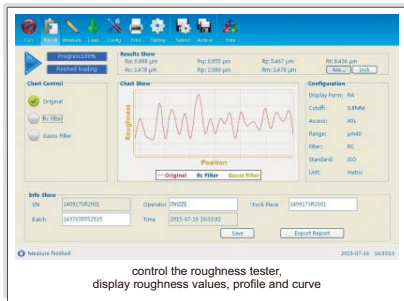

screen display

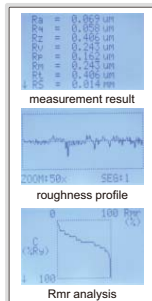

adjustable stand (included)



probe cover (included)



wireless printer (optional)



test stand (optional)



### SPECIFICATION

|                     |  |           |
|---------------------|--|-----------|
| List Price (₹)      | 122195   |           |
| Promotion Price (₹) | 79343  |           |
| Parameters          | Ra, Rq, Rz, Rv, Rp, Rm, Rt, RS, Rsm, R3z, R3y, Rz (JIS), Rku, Rsk, Rmax, Rpc |           |
| Range               | 160µm  |           |
| Accuracy            | ±10%   |           |
| Resolution (Ra)     | 0.001µm  |           |
| Probe               | type   | inductive |
|                     | stylus radius/angle  | 5µm/90°   |
|                     | stylus material  | diamond   |
| Measuring force     | 4mN  |           |
| Measuring unit      | µm/µin   |           |
| Cut off             | 0.25/0.8/2.5mm   |           |
| Number of cut-offs  | 1 to 5   |           |
| Traverse speed      | 0.5mm/s, 1mm/s   |           |
| Memory              | 100 measurement results  |           |
| Output              | USB and bluetooth  |           |
| Power               | built-in rechargeable battery  |           |
| Dimension (L×W×H)   | 140×52×48mm  |           |
| Weight              | 440g   |           |

### STANDARD DELIVERY

|                               |              |
|-------------------------------|--------------|
| Main unit                     | 1 pc         |
| Standard probe                | 1 pc         |
| Calibration block and support | 1 pc of each |
| Adjustable stand              | 1 pc         |
| Probe cover                   | 1 pc         |
| USB cable and software for PC | 1 pc         |
| Android APP for mobile device | 1 pc         |
| AC/DC adapter                 | 1 pc         |

### OPTIONAL ACCESSORY

|                   |                  |
|-------------------|------------------|
| Extension rod     | ISR-C100-ER      |
| Groove probe      | ISR-C100-130     |
| Deep groove probe | ISR-C100-131     |
| Test stand        | ISR-C100-STAND   |
| Wireless printer  | ISR-C100-PRINTER |

Unit:mm

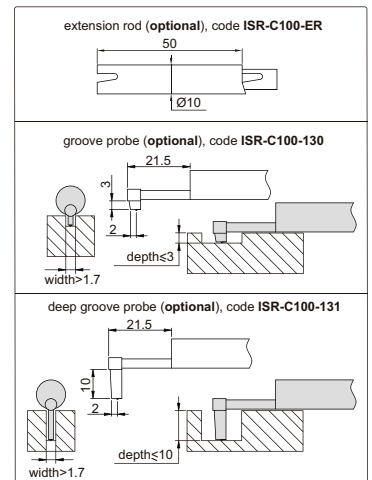

**ROUGHNESS TESTER(SEPARABLE TYPE)  
CODE ISR-C300**

CAN BE OPERATED BY  
COMPUTER OR MOBILE PHONE

DATA  
OUTPUT

BLUETOOTH

- ▶ Roughness tester can be operated by mobile phone (only android system) or computer
- ▶ Data can be output to Excel by connecting with computer via bluetooth or USB cable
- ▶ Support bluetooth printer
- ▶ 22 roughness parameters
- ▶ Meet ISO, DIN, ANSI, JIS standards
- ▶ Display roughness values, profile and curve
- ▶ Memory of maximum 100 data and waveform
- ▶ Built-in lithium battery, working time more than 50 hours
- ▶ Automatic power off



probe and main unit can be combined together

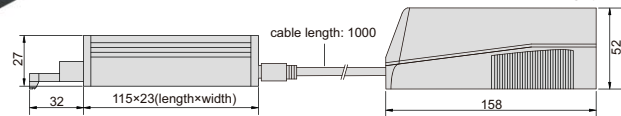

roughness tester screen display

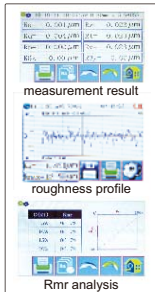

connect mobile phone via bluetooth (only android system)



operate roughness tester by mobile phone, display roughness values, profile and curve

connect computer via USB cable (software is included)

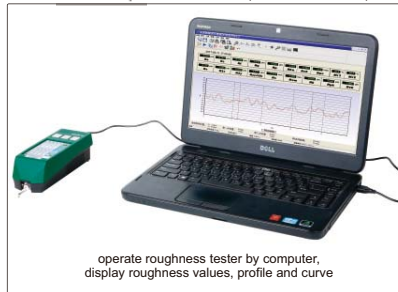

operate roughness tester by computer, display roughness values, profile and curve

magnetic stand adapter (included)



can be installed on magnetic stands

height gage adapter (optional)

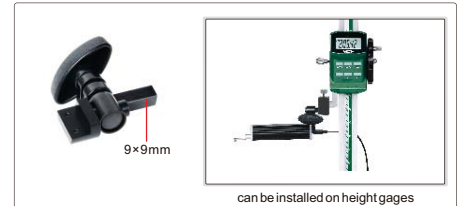

can be installed on height gages

data can be output to Excel by connecting with computer via bluetooth or USB cable



adjustable stand (included)



bluetooth printer (optional)



NOTE: Please confirm whether the adapter can fit your height gages. When using INSIZE height gages, please use the dial test indicator holder of height gages

optional probes

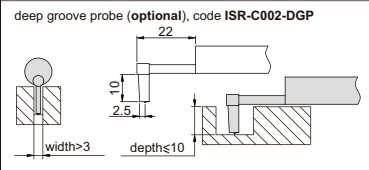
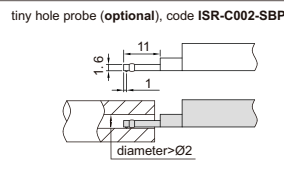
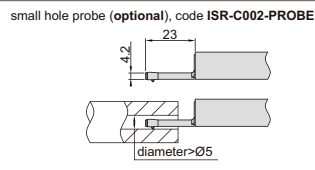
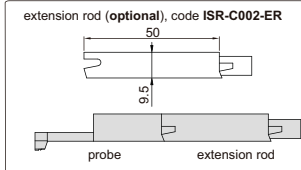

**SPECIFICATION**

|                     |                     |  |
|---------------------|---------------------|--|
| List Price (₹)      |                     | 119005   |
| Promotion Price (₹) |                     | 101154   |
| Parameters          |                     | Ra, Rz, Rq, Rv, Rp, Rs, R3z, R3y, Rt, Rc, Rz (JIS), Rk, Rku, Rsm, Rpc, Rpk, Rvk, Rsk, Mr1, Mr2, Ry, Rmax |
| Range               | X axis              | 17.5mm   |
|                     | Z axis              | 320µm(-160µm~160µm)  |
| Accuracy            |                     | ±10%   |
| Resolution (Ra)     |                     | 0.002µm/±20µm 0.004µm/±40µm<br>0.006µm/±80µm 0.02µm/±160µm   |
| Probe               | type                | inductive  |
|                     | stylus radius/angle | 5µm/90°  |
|                     | stylus material     | diamond  |
| Measuring force     |                     | 4mN  |
| Measuring unit      |                     | µm/µin   |
| Cut off             |                     | 0.25/0.8/2.5mm   |
| Number of cut-offs  |                     | 1~5  |
| Traverse speed      |                     | 0.135mm/s, 0.5mm/s, 1mm/s  |
| Memory              |                     | 100 measurement results  |
| Output              |                     | USB and bluetooth  |
| Power               |                     | built-in rechargeable battery  |
| Dimension (L×W×H)   |                     | 158×64×52mm  |
| Weight              |                     | 400g   |

**STANDARD DELIVERY**

|                                   |             |
|-----------------------------------|-------------|
| Main unit                         | 1pc         |
| Standard probe                    | 1pc         |
| Calibration block and support     | 1pc of each |
| Connecting cable (long and short) | 1pc of each |
| Magnetic stand adapter            | 1pc         |
| Adjustable stand                  | 1pc         |
| Touch pen                         | 1pc         |
| USB cable and software            | 1pc         |
| AC/DC adapter                     | 1pc         |

**OPTIONAL ACCESSORY**

|                                 |                   |
|---------------------------------|-------------------|
| Extension rod                   | ISR-C002-ER       |
| Small hole probe                | ISR-C002-PROBE    |
| Tiny hole probe                 | ISR-C002-SBP      |
| Deep groove probe               | ISR-C002-DGP      |
| Bluetooth printer               | ISR-C002-PRINTER  |
| Height gage adapter             | ISR-C300-LB1      |
| Bluetooth receiver              | ISR-C300-RECEIVER |
| Support for flat surface        | ISR-C300-COVER1   |
| Support for cylindrical surface | ISR-C300-COVER2   |

probe support (optional)

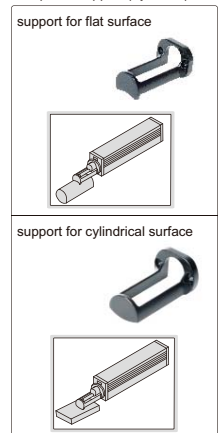

## ROUGHNESS TESTER CODE ISR-C002

CAN BE CONTROLLED  
BY COMPUTER

DATA  
OUTPUT

- ▶ 21 roughness parameters
- ▶ Display roughness values, profile and curve
- ▶ Memory of maximum 100 results
- ▶ Automatic power off



software CD (included)



printer (optional)



software (included)

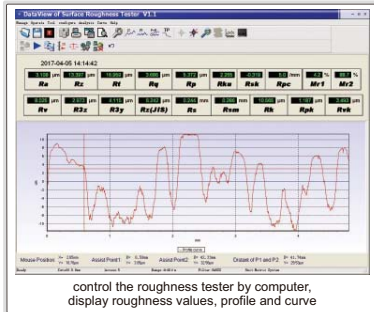

control the roughness tester by computer,  
display roughness values, profile and curve

screen display

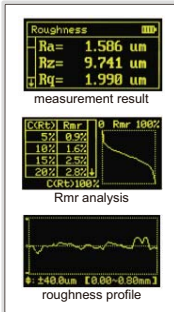

roughness profile

light duty test stand (optional)



the maximum workpiece  
height is 220mm

heavy duty test stand (optional)



the maximum workpiece  
height is 310mm

adjustable stand (included)



probe cover (included)



put the small workpieces  
directly under the probe  
for measurement

Unit: mm

### SPECIFICATION

|                     |  |
|---------------------|--|
| List Price (₹)      | 105323   |
| Promotion Price (₹) | 79343  |
| Parameters          | Ra, Rz, Rq, Rv, Rp, RS, R3z, R3y, Rt, Rz (JIS), Rk, Rku, Rsm, Rpc, Rpk, Rvk, Rsk, Mr1, Mr2, Ry (JIS), Rmax |
| Range               | 160µm  |
| Accuracy            | ±10%   |
| Resolution (Ra)     | 0.001µm  |
| Probe               | type inductive<br>stylus radius/angle 5µm/90°<br>stylus material diamond                                   |
| Measuring force     | 4mN  |
| Measuring unit      | µm/µin   |
| Cut off             | 0.25/0.8/2.5mm   |
| Number of cut-offs  | 1 to 5   |
| Traverse speed      | 0.5mm/s, 1mm/s   |
| Memory              | 100 measurement results  |
| Output              | USB  |
| Power               | built-in rechargeable battery  |
| Dimension (L×W×H)   | 141×55×40mm  |
| Weight              | 400g   |

### STANDARD DELIVERY

|                               |              |
|-------------------------------|--------------|
| Main unit                     | 1 pc         |
| Standard probe                | 1 pc         |
| Calibration block and support | 1 pc of each |
| Adjustable stand              | 1 pc         |
| Probe cover                   | 1 pc         |
| Software                      | 1 pc         |
| AC/DC adapter                 | 1 pc         |

### OPTIONAL ACCESSORY

|                       |                  |
|-----------------------|------------------|
| Extension rod         | ISR-C002-ER      |
| Transverse rod        | ISR-C002-TR      |
| Deep groove probe     | ISR-C002-DGP     |
| Small hole probe      | ISR-C002-SBP     |
| Light duty test stand | ISR-C002-STAND1  |
| Heavy duty test stand | ISR-C002-STAND   |
| Printer               | ISR-C002-PRINTER |

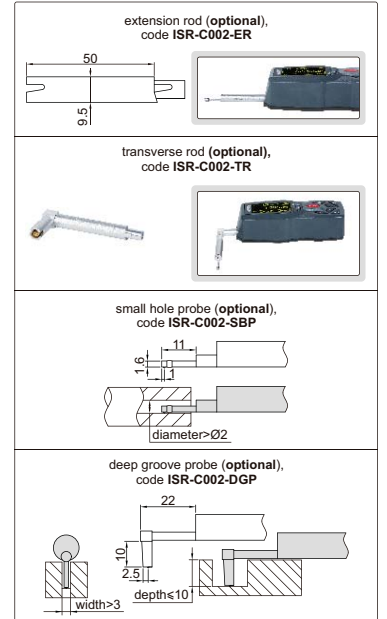

## ROUGHNESS TESTER CODE ISR-C003



calibration block (included)

- ▶ Unit: µm, µin
- ▶ Automatic power off



### STANDARD DELIVERY

|                   |      |
|-------------------|------|
| Main unit         | 1 pc |
| Calibration block | 1 pc |
| AC/DC adapter     | 1 pc |

### SPECIFICATION

|                     |   |
|---------------------|---|
| List Price (₹)      | 79213   |
| Promotion Price (₹) | 64803   |
| Parameters          | Ra, Rz, Rq, Rt  |
| Range               | Ra, Rq: 0.05~15µm<br>Rz, Rt: 0.1~50µm   |
| Accuracy            | ±10%  |
| Resolution (Ra)     | 0.01µm  |
| Probe               | type piezoelectric<br>stylus radius/angle 10µm/90°<br>stylus material diamond |
| Measuring force     | 5mN   |
| Measuring unit      | µm/µin  |
| Cut off             | 0.25/0.8/2.5mm  |
| Evaluation length   | 1.25mm for cut off 0.25mm<br>4mm for cut off 0.8mm<br>5mm for cut off 2.5mm   |
| Traverse speed      | 0.75mm/s  |
| Power               | built-in rechargeable battery   |
| Dimension (L×W×H)   | 106×70×24mm   |
| Weight              | 200g  |

MANUAL 360° SWIVEL VIDEOSCOPE

**TUNGSTEN WIRE WEAVED CABLE RESISTANCE TO BREAK AND WEAR**

**IP64 WATERPROOF**

**ISV-2000DS**

power on/off  
LED illumination on the back  
USB port  
charge port  
video output  
SD card  
5" LCD  
take video  
zoom manual joystick to bend the lens in any direction  
tungsten wire weaved cable  
take picture  
lens with adjustable LED illumination  
rechargeable battery

the cable is interchangeable

bend in any direction  
360° swivel in clockwise and counter-clockwise  
bending range of lens  
lens with LED adjustable illumination  
focus distance  
angle of view

SPECIFICATION

|                     |                    |  |
|---------------------|--------------------|--|
| Code                | ISV-2000DS         |  |
| List Price (₹)      | 291204             |  |
| Promotion Price (₹) | 262083             |  |
| Lens                | diameter (D)       | 6.5mm  |
|                     | focus distance (F) | 15mm~∞   |
|                     | bending range (α)  | ±160°  |
|                     | angle of view (θ)  | 90°  |
|                     | illumination       | 8 pcs LED  |
|                     | pixel              | 0.44M  |
|                     | resolution         | 800×480  |
|                     | dust/waterproof    | IP64   |
| Cable               | length             | 1.5m   |
|                     | type               | tungsten wire weaved cable   |
| Main unit           | function           | take picture, take video   |
|                     | file format        | picture: JPG, video: AVI   |
|                     | image process      | brightness, image quality zoom (1X, 2X, 3X)  |
|                     | memory             | 8G SD card   |
|                     | output             | TV, USB  |
|                     | power supply       | rechargeable battery (for 4 hours working)<br>AC/DC adapter (for continuous working) |
| Weight              | 650g               |  |

STANDARD DELIVERY

|                    |      |
|--------------------|------|
| Main unit          | 1 pc |
| Cable with lens    | 1 pc |
| 8G SD card         | 1 pc |
| AC/DC adapter      | 1 pc |
| Video output cable | 1 pc |
| USB cable          | 1 pc |

COATING THICKNESS GAGE  
CODE 9501-1200

FOR MAGNETIC AND NON-MAGNETIC SUBSTRATES

DATA OUTPUT

SPECIFICATION

|  |  |                                      |   |  |
|--|--|--------------------------------------|---|--|
| List Price (₹)                               | 22389  |                                      |   |  |
| Promotion Price (₹)                          | 19966  |                                      |   |  |
| Probe type                                   | Fe (included)<br>magnetic induction probe  | NFe (optional)<br>eddy current probe | Fe90 (optional)<br>magnetic induction probe for bores and grooves | Fe10 (optional)<br>magnetic induction probe with big range |
| Measuring range                              | 0~1250µm   | 0~1250µm                             | 0~1250µm  | 500~10000µm  |
| Accuracy                                     | ±(3%L+1)µm (range≤1250µm)<br>±(3%L+10)µm (range>1250µm) L is measuring thickness in µm |                                      |   |  |
| Resolution                                   | 0.1µm (range<100µm)<br>1µm (range≥100µm)   |                                      |   |  |
| Measuring mode                               | continuous and single  |                                      |   |  |
| Minimum substrate thickness                  | 0.5mm  | 0.3mm                                | 0.5mm   | 2mm  |
| Minimum measuring area                       | Ø7mm   | Ø5mm                                 | Ø7mm  | Ø40mm  |
| Minimum curvature radius of convex workpiece | 1.5mm  | 3mm                                  | -   | 10mm   |
| Memory                                       | 500  |                                      |   |  |
| Power supply                                 | 2x1.5V AA batteries  |                                      |   |  |
| Dimension                                    | 128x68x32mm  |                                      |   |  |
| Weight                                       | 340g   |                                      |   |  |

STANDARD DELIVERY

|   |       |
|---|-------|
| Main unit   | 1 pc  |
| Magnetic induction probe (Fe)                         | 1 pc  |
| Zero calibration block for Fe probe                   | 1 pc  |
| Calibration foils (50µm, 100µm, 250µm, 500µm, 1000µm) | 1 set |
| 1.5V AA battery                                       | 2 pcs |
| USB cable and software                                | 1 pc  |

OPTIONAL ACCESSORY

|   |                |
|---|----------------|
| Eddy current probe (NFe) with zero calibration block  | 9501-1200-NFE  |
| Magnetic induction probe (Fe90) for bores and grooves | 9501-1200-FE90 |
| Magnetic induction probe (Fe10) with big range        | 9501-1200-FE10 |

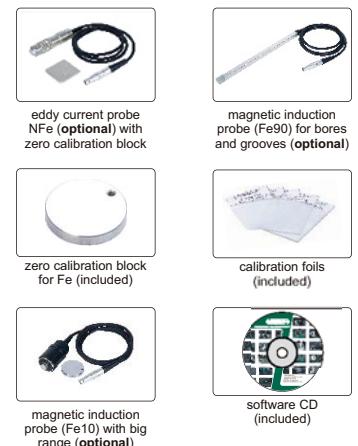

## ULTRASONIC THICKNESS GAGE (BASIC MODEL) CODE ISU-100D



ATTENTION: NOT SUITABLE FOR CASTING WORKPIECES



- ▶ Measure the thickness from one side of object, suitable for pipe, tank, etc.
- ▶ Applicable material: metal, plastic, glass, nylon, resin, ceramic, ice

### STANDARD DELIVERY

|               |          |
|---------------|----------|
| Main unit     | 1 pc     |
| Transducer    | 1 pc     |
| Couplant      | 1 bottle |
| Battery (AAA) | 2 pcs    |



### SPECIFICATION

|                                      |   |        |
|--------------------------------------|---|--------|
| List Price (₹)                       | 38114   |        |
| Promotion Price (₹)                  | 24387   |        |
| Measuring range                      | 0.8-300mm   |        |
| Resolution                           | 0.01mm (range<100mm)  |        |
|                                      | 0.1mm (range≥100mm)   |        |
| Accuracy                             | ±0.04mm (range<10mm)  |        |
|                                      | ±(0.04+H/1000)mm (range 10~100mm)                                 |        |
|                                      | ±H/333mm (range≥100mm)<br>H is the thickness to be measured in mm |        |
| Transducer                           | frequency   | 5MHz   |
|                                      | diameter (Ød)   | 10.8mm |
| Minimum size of pipe for measurement | 20×1.2mm (diameter × wall thickness)                              |        |
| Applicable temperature               | <60°C   |        |
| Velocity                             | 1000-9999m/s  |        |
| Power supply                         | 2×AAA batteries   |        |
| Dimension                            | 114×64×28mm   |        |
| Weight                               | 200g  |        |

## LASER DISTANCE METER

- ▶ Large display with backlight
- ▶ Unit: m, ft, in
- ▶ Distance, area, volume and height measurement
- ▶ Continuous measuring mode to track maximum and minimum value
- ▶ Memory of 99 measurement values
- ▶ Automatic power off: laser 20s, main unit 150s

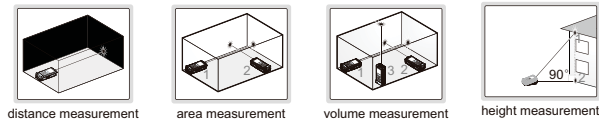

### SPECIFICATION

|                     |  |          |
|---------------------|--|----------|
| Code                | 9561-40                                | 9561-80  |
| List Price (₹)      | 5561                                   | 7077     |
| Promotion Price (₹) | 5005                                   | 5750     |
| Measuring range     | 0.05-40m                               | 0.05-80m |
| Accuracy            | ±3mm                                   |          |
| Resolution          | 1mm, 10mm, 0.1", 0.01ft                |          |
| Measuring speed     | 0.5 second                             |          |
| Laser type          | 635nm, Class II, <1mW                  |          |
| Power supply        | 3xAAA batteries, for 4000 measurements |          |
| Dimension (L×W×H)   | 120x60x28mm                            |          |
| Weight              | 175g                                   |          |

### STANDARD DELIVERY

|               |       |
|---------------|-------|
| Main unit     | 1 pc  |
| Battery (AAA) | 3 pcs |

## DIGITAL ANEMOMETER CODE 9331-40

DATA OUTPUT

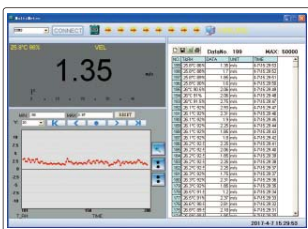

software (included), display measurement values and graph, save and output data



- ▶ Measure velocity, flow, temperature and relative humidity
- ▶ Velocity unit: m/s, km/h, mil/h, ft/m, ft/s, knots
- ▶ Flow unit: CMS (cubic meter per second), CMM (cubic meter per minute), CFM (cubic feet per minute)
- ▶ Temperature type: ambient, dew point, wet bulb
- ▶ Maximum and minimum modes
- ▶ Automatic power off

### STANDARD DELIVERY

|                        |      |
|------------------------|------|
| Main unit              | 1 pc |
| USB cable and software | 1 pc |
| 9V battery             | 1 pc |



software CD (included)

### SPECIFICATION

|                        |                   |   |
|------------------------|-------------------|---|
| List Price (₹)         | 6398              |   |
| Promotion Price (₹)    | 5706              |   |
| Measuring range        | velocity          | 0.8-30m/s, 1.4-108km/h, 0.9-67.2mil/h, 1.3-98.5ft/s, 78-5900ft/m, 0.8-58.3knots |
|                        | flow              | 0-9999CMS, 0-99990CMM, 0-99990CFM   |
|                        | temperature       | -20-60°C/-4~140°F   |
| Accuracy               | relative humidity | 0-100%RH  |
|                        | velocity          | ±(2%+0.5) for m/s, km/h, mil/h, ft/s, knots<br>±(2%+50) for ft/m                |
|                        | temperature       | ±1.5°C/±2.7°F   |
| Resolution             | relative humidity | ±3% (20-80%RH), ±5% (<20%RH or >80%RH)  |
|                        | velocity          | 0.01m/s, 0.01km/h, 0.01mil/h, 0.01ft/s, 1ft/m, 0.01knots                        |
|                        | flow              | 0.01CMS, 0.1CMM, 0.1CFM   |
| Flowing area range     | temperature       | 0.1°C/0.1°F   |
|                        | relative humidity | 0.1%RH  |
|                        | velocity          | 0-9.999m²/0-9.999ft²  |
| Sampling time          | 0.4s              |   |
| Maximum working height | 2000m             |   |
| Output                 | USB               |   |
| Power supply           | 9V battery        |   |
| Dimension              | 165×85×38mm       |   |
| Weight                 | 200g              |   |

**DIGITAL MOISTURE METER  
CODE 9341-50**

- ▶ Suitable for wood, smooth cement, hard gypsum, mixed mortar, brick, etc.
- ▶ Measure moisture, temperature and relative humidity
- ▶ Temperature type: ambient, dew point, wet bulb
- ▶ Maximum and minimum modes
- ▶ Automatic power off



**STANDARD DELIVERY**

|               |       |
|---------------|-------|
| Main unit     | 1 pc  |
| Battery (AAA) | 2 pcs |

**SPECIFICATION**

|                     |   |                   |
|---------------------|---|-------------------|
| List Price (₹)      | 4015  |                   |
| Promotion Price (₹) | 3581  |                   |
| Measuring depth     | 0~50mm  |                   |
| Measuring range     | Moisture  | 0~60%             |
|                     | temperature   | -10~50°C/14~122°F |
|                     | relative humidity   | 0~100%RH          |
| Accuracy            | Moisture  | ±2%               |
|                     | temperature   | ±2%               |
|                     | relative humidity   | ±5%RH             |
| Resolution          | Moisture  | 0.1%              |
|                     | temperature   | 0.1°C/0.1°F       |
|                     | relative humidity   | 0.1%RH            |
| Sampling time       | 0.5s for moisture<br>1s for temperature and relative humidity |                   |
| Power supply        | 2×AAA batteries   |                   |
| Dimension           | 130×56×29mm   |                   |
| Weight              | 206g  |                   |

**DIGITAL SOUND LEVEL METER  
CODE 9351-130**

DATA OUTPUT

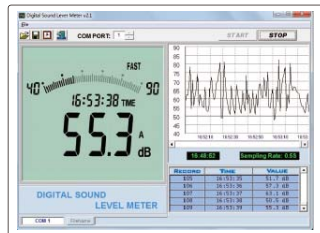

software (included), display measurement values and graph, save and output data



software CD (included)



- ▶ Automatically select best range: 30~80dB, 40~90dB, 50~100dB, 60~110dB, 70~120dB, 80~130dB
- ▶ Over range indicator
- ▶ Real time, average, maximum modes
- ▶ Memory 16000 measurement values
- ▶ AC signal output: 0.707 Vrms at FS, impedance approx. 600Ω
- ▶ DC signal output: 10mV/dB, impedance approx. 100Ω
- ▶ Automatic power off

**SPECIFICATION**

|                     |                                      |
|---------------------|--------------------------------------|
| List Price (₹)      | 9580                                 |
| Promotion Price (₹) | 8544                                 |
| Measuring range     | 30~130dB                             |
| Accuracy            | ±2dB                                 |
| Resolution          | 0.1dB                                |
| Sampling time       | 0.5s for digital, 0.05s for analogue |
| Response time       | fast: 125ms, slow: 1s                |
| Frequency           | 30Hz~8KHz                            |
| Frequency weighting | A/C                                  |
| Microphone          | electret condenser type              |
| Output              | RS232, AC/DC                         |
| Power supply        | 6xAAA batteries                      |
| Dimension           | 265x80x69mm                          |
| Weight              | 317g                                 |

**STANDARD DELIVERY**

|                          |       |
|--------------------------|-------|
| Main unit                | 1 pc  |
| RS232 cable and software | 1 pc  |
| Output connector         | 1 pc  |
| Battery (AAA)            | 6 pcs |

**NON-CONTACT DIGITAL TACHOMETER  
CODE 9221-999**

- ▶ Maximum and minimum modes
- ▶ Memory 100 measurement values
- ▶ Automatic power off

reflection sticker (included)

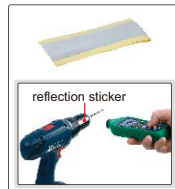

**STANDARD DELIVERY**

|                    |        |
|--------------------|--------|
| Main unit          | 1 pc   |
| Reflection sticker | 1 roll |
| Battery (AAA)      | 4 pcs  |

**SPECIFICATION**

|                     |                              |
|---------------------|------------------------------|
| List Price (₹)      | 4023                         |
| Promotion Price (₹) | 3362                         |
| Measuring range     | 50~99999RPM                  |
| Accuracy            | ±(0.03%+2) RPM               |
| Resolution          | 0.01RPM (range 50~99.99RPM)  |
|                     | 0.1RPM (range 100~9999.9RPM) |
|                     | 1RPM (range 10000~99999RPM)  |
| Measuring distance  | 50~250mm                     |
| Power supply        | 4×AAA batteries              |
| Dimension           | 155×60×27mm                  |
| Weight              | 118g                         |

## CONTACT DIGITAL TACHOMETER CODE 9222-199

- ▶ Unit: RPM, m/min, m/sec, ft/min, ft/sec, in/min
- ▶ Maximum and minimum modes
- ▶ Memory 100 measurement values
- ▶ Automatic power off

### STANDARD DELIVERY

|                           |       |
|---------------------------|-------|
| Main unit                 | 1 pc  |
| Wheel with 0.1m perimeter | 1 pc  |
| Wheel with 6" perimeter   | 1 pc  |
| Cone cavity head          | 1 pc  |
| Cone head                 | 1 pc  |
| Extension rod             | 1 pc  |
| Battery (AAA)             | 4 pcs |



### SPECIFICATION

|                     |  |
|---------------------|--|
| List Price (₹)      | 3787   |
| Promotion Price (₹) | 3165   |
| Measuring range     | 50~19999RPM  |
| Accuracy            | ±(0.03%+2) RPM   |
| Resolution          | 0.01RPM (range 50~99.99RPM)<br>0.1RPM (range 100~9999.9RPM)<br>1RPM (range 10000~19999RPM) |
| Power supply        | 4×AAA batteries  |
| Dimension           | 183×60×27mm  |
| Weight              | 122g   |

## PEN-TYPE DIGITAL MULTIMETER CODE 9241-ML200

- ▶ Auto/manual ranging
- ▶ Maximum mode
- ▶ Data hold
- ▶ Low battery display
- ▶ Auto power off
- ▶ Safety rating: CAT III 600V



### SPECIFICATION

| Function          | Range  | Resolution                | Accuracy               |
|-------------------|--|---------------------------|------------------------|
| DC Voltage        | 200mV/2V/20V/200V/600V   | 0.1mV/1mV/10mV/0.1V/1V    | ±(0.7%+2)              |
| AC Voltage        | 200mV/2V/20V/200V<br>600V  | 0.1mV/1mV/10mV/0.1V<br>1V | ±(0.8%+3)<br>±(1.0%+3) |
| DC Current        | 20mA/200mA   | 10µA/0.1mA                | ±(1.5%+3)              |
| AC Current        | 20mA/200mA   | 10µA/0.1mA                | ±(2.0%+3)              |
|                   | 200Ω   | 0.1Ω                      | ±(1.0%+3)              |
| Resistance        | 2kΩ/20kΩ/200kΩ/2MΩ   | 1Ω/10Ω/0.1kΩ/1kΩ          | ±(1.0%+1)              |
|                   | 20MΩ   | 10kΩ                      | ±(1.0%+5)              |
| NCV               | >50V AC  |                           |                        |
| Logic level test  | <1.5V (green LED on)<br>1.5~3.5V (green & red LED off)<br>>3.5V (red LED on) |                           |                        |
| Diode             | open circuit voltage 1.5V  |                           |                        |
| Continuity buzzer | <60Ω   |                           |                        |
| Power supply      | 2×1.5V AAA batteries   |                           |                        |

|                     |      |
|---------------------|------|
| List Price (₹)      | 2314 |
| Promotion Price (₹) | 2083 |

### STANDARD DELIVERY

|              |       |
|--------------|-------|
| Main unit    | 1 pc  |
| Probe        | 1 pc  |
| Clip         | 2 pcs |
| 1.5V battery | 2 pcs |

## DIGITAL MULTIMETER CODE 9242-ML100

- ▶ Data hold
- ▶ Display backlight
- ▶ Low battery display
- ▶ Safety rating: CAT II 600V

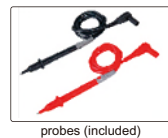

### SPECIFICATION

| Function          | Range                             | Resolution                         | Accuracy  |
|-------------------|-----------------------------------|------------------------------------|---|
| DC Voltage        | 200mV/2V/20V/200V<br>600V         | 0.1mV/1mV/10mV/0.1V<br>1V          | ±(0.5%+3)<br>±(0.8%+5)                            |
| AC Voltage        | 200V/600V                         | 0.1V/1V                            | ±(1.2%+10)  |
| DC Current        | 200µA/2mA<br>20mA<br>200mA<br>10A | 0.1µA/1µA<br>10µA<br>0.1mA<br>10mA | ±(1.0%+3)<br>±(1.0%+5)<br>±(1.5%+5)<br>±(3.0%+10) |
| Resistance        | 200Ω<br>2kΩ/20kΩ/200kΩ<br>2MΩ     | 0.1Ω<br>1Ω/10Ω/0.1kΩ<br>1kΩ        | ±(0.8%+5)<br>±(0.8%+2)<br>±(1.0%+5)               |
| Diode             | open circuit voltage 3.0V         |                                    |   |
| Continuity buzzer | <70±30Ω                           |                                    |   |
| Transistor hFE    | measuring range 0~1000            |                                    |   |
| Power supply      | 1×9V 6F22/NEDA 1604 battery       |                                    |   |

|                     |      |
|---------------------|------|
| List Price (₹)      | 1282 |
| Promotion Price (₹) | 1154 |

### STANDARD DELIVERY

|            |       |
|------------|-------|
| Main unit  | 1 pc  |
| Probe      | 2 pcs |
| 9V battery | 1 pc  |



**AC DIGITAL CLAMP METER  
CODE 9243-CA600**

- ▶ Auto/manual ranging
- ▶ Maximum mode
- ▶ Data hold
- ▶ Display backlight
- ▶ Work light
- ▶ Low battery display
- ▶ Auto power off
- ▶ Safety rating: CAT III 600V



probes (included)



**SPECIFICATION**

| Function          | Range                       | Resolution            | Accuracy   |
|-------------------|-----------------------------|-----------------------|------------|
| DC Voltage        | 200mV/2V/20V/200V           | 0.1mV/1mV/10mV/0.1V   | ±(0.8%+2)  |
|                   | 600V                        | 1V                    | ±(1.0%+2)  |
| AC Voltage        | 200mV                       | 0.1mV                 | ±(1.0%+10) |
|                   | 2V/20V/200V                 | 1mV/10mV/0.1V         | ±(1.0%+5)  |
|                   | 600V                        | 1V                    | ±(1.2%+5)  |
| AC Current        | 2A(≤0.5A)                   | 1mA                   | ±(3.5%+20) |
|                   | 2A                          | 1mA                   | ±(3.0%+10) |
|                   | 20A                         | 10mA                  | ±(3.0%+10) |
|                   | 200A                        | 0.1A                  | ±(2.5%+10) |
|                   | 600A                        | 1A                    | ±(1.5%+5)  |
| Resistance        | 200Ω/2kΩ/20kΩ/200kΩ/2MΩ     | 0.1Ω/1Ω/10Ω/0.1kΩ/1kΩ | ±(1.2%+2)  |
|                   | 20MΩ                        | 10kΩ                  | ±(2.0%+5)  |
| Diode             | open circuit voltage 3.0V   |                       |            |
| Continuity buzzer | <70±30Ω                     |                       |            |
| Power supply      | 1×9V 6F22/NEDA 1604 battery |                       |            |

|                     |      |
|---------------------|------|
| List Price (₹)      | 2563 |
| Promotion Price (₹) | 2307 |

**STANDARD DELIVERY**

|              |       |
|--------------|-------|
| Main unit    | 1 pc  |
| Probe        | 2 pcs |
| 1.5V battery | 3 pcs |

**WEIGHING SCALES (OIML CERTIFICATE)**

- ▶ LCD display, with backlight
- ▶ Zero-setting, subtracting tare value
- ▶ Overload alarm
- ▶ Automatic power off
- ▶ OIML certificate (No. 0200-NAWI-04601)

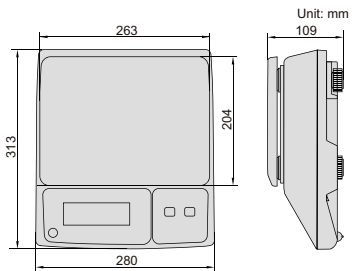

8002-30M

ATTENTION: NO DATE OUTPUT



| Code                  | 8002-6M  | 8002-15M | 8002-30M |
|-----------------------|--|----------|----------|
| List Price (₹)        | 11120  | 11120    | 11120    |
| Promotion Price (₹)   | 10008  | 10008    | 10008    |
| Capacity              | 3/6kg  | 6/15kg   | 15/30kg  |
| Minimum capacity      | 20g  | 40g      | 100g     |
| Readout               | 1g/2g  | 2g/5g    | 5g/10g   |
| Resolution            | 2×3000e  |          |          |
| Operating temperature | -10~40°C   |          |          |
| Power                 | rechargeable battery (6V/3.2Ah)<br>power adapter (12V/500mA) |          |          |
| Dimensions of pan     | 263×204mm  |          |          |

**WEIGHING SCALES (HIGH PRECISION)**

- ▶ LCD display, with backlight
- ▶ Zero-setting, subtracting tare value
- ▶ Overload alarm
- ▶ Automatic power off

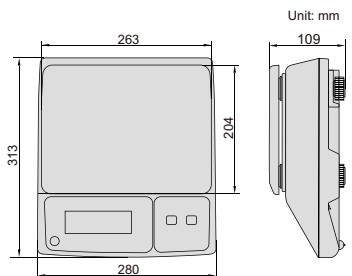

8001-30

ATTENTION: NO DATE OUTPUT

| Code                  | 8001-6   | 8001-15 | 8001-30 |
|-----------------------|--|---------|---------|
| List Price (₹)        | 11120  | 11120   | 11120   |
| Promotion Price (₹)   | 10008  | 10008   | 10008   |
| Capacity              | 6kg  | 15kg    | 30kg    |
| Minimum capacity      | 4g   | 10g     | 20g     |
| Readout               | 0.2g   | 0.5g    | 1g      |
| Resolution            | 3000d  |         |         |
| Operating temperature | -10~40°C   |         |         |
| Power                 | rechargeable battery (6V/3.2Ah)<br>power adapter (12V/500mA) |         |         |
| Dimensions of pan     | 263×204mm  |         |         |

## COUNTING SCALES

ATTENTION: NO DATE OUTPUT

- ▶ LCD display, with backlight
- ▶ Zero-setting, subtracting tare value, counting, accumulation, checking alarm
- ▶ Overload alarm

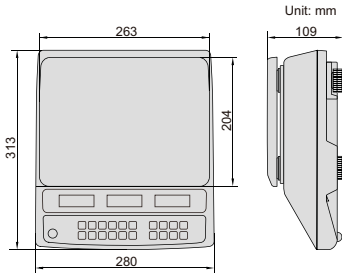

8101-30

| Code                  | 8101-6   | 8101-15 | 8101-30 |
|-----------------------|--|---------|---------|
| List Price (₹)        | 11120  | 11120   | 11120   |
| Promotion Price (₹)   | 10008  | 10008   | 10008   |
| Capacity              | 6kg  | 15kg    | 30kg    |
| Minimum capacity      | 4g   | 10g     | 20g     |
| Readout               | 0.2g   | 0.5g    | 1g      |
| Resolution            | 3000d  |         |         |
| Operating temperature | -10~40°C   |         |         |
| Power                 | rechargeable battery (6V/3.2Ah)<br>power adapter (12V/500mA) |         |         |
| Dimensions of pan     | 263×204mm  |         |         |

## WEIGHT SETS



### SPECIFICATION AND SHAPE

| Weight      | Specification |             |
|-------------|---------------|-------------|
|             | 1mg~100g      | 1mg~200g    |
| 1mg         | ●             | ●           |
| 2mg         | ● ●*          | ● ●*        |
| 5mg         | ●             | ●           |
| 10mg        | ●             | ●           |
| 20mg        | ● ●*          | ● ●*        |
| 50mg        | ●             | ●           |
| 100mg       | ●             | ●           |
| 200mg       | ● ●*          | ● ●*        |
| 500mg       | ●             | ●           |
| 1g          | ■             | ■           |
| 2g          | ■ ■*          | ■ ■*        |
| 5g          | ■             | ■           |
| 10g         | ■             | ■           |
| 20g         | ■ ■*          | ■ ■*        |
| 50g         | ■             | ■           |
| 100g        | ■             | ■           |
| 200g        | ■             | ■ ■*        |
| Quantity    | 21 pcs        | 23 pcs      |
| Total range | 1mg~211.11g   | 1mg~611.11g |

- sheet
- cylinder
- \* sheet, with mark
- \* cylinder, with mark



- ▶ Supplied with manufacturer inspection certificate

### CLASS AND MATERIAL

| Specification | M1 (304 stainless steel) | List Price (₹) | Promotion Price (₹) |
|---------------|--------------------------|----------------|---------------------|
| 1mg~100g      | 8910-100GM1              | 5575           | 5017                |
| 1mg~200g      | 8910-200GM1              | 7644           | 6879                |

## PORTABLE REFRACTOMETER CODE ISQ-RM30

SUITABLE FOR WATER BASED COOLANT

- ▶ Quickly measure the concentration of coolant
- ▶ Refer to the refraction factor of coolant, for example: the refraction factor of grinding emulsion is 2.1, the reading value is 6%, so the actual concentration is  $(2.1 \times 6\%) = 12.6\%$



### SPECIFICATION

|                     |             |
|---------------------|-------------|
| List Price (₹)      | 5730        |
| Promotion Price (₹) | 3690        |
| Measuring range     | 0~32%       |
| Graduation          | 0.2%        |
| Dimension           | 27×40×160mm |
| Weight              | 175g        |

**BLOCK LEVELS**

- ▶ V-groove on bottom for shafts (shafts dia. 15~70mm)
- ▶ With transverse vial
- ▶ Supplied with adjusting wrench



ATTENTION: BASIC MODEL



4903-200A

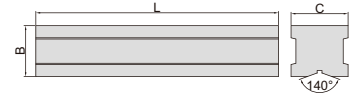

Sensitivity 0.02mm/m ( $\approx 0.001^\circ$ ) (mm)

| Code      | Length (L) | B  | C  | List Price (₹) | Promotion Price (₹) |
|-----------|------------|----|----|----------------|---------------------|
| 4903-150A | 150mm      | 40 | 45 | 8132           | 6354                |
| 4903-200A | 200mm      | 42 | 47 | 8573           | 6995                |

**CROSS-LINE LASER LEVEL  
CODE 4917-30**

- ▶ Red horizontal and vertical cross laser lines
- ▶ Self-leveling within  $\pm 3^\circ$ , self-leveling time within 4s, "out of  $\pm 3^\circ$ " audible and visual warning
- ▶ Folding legs for angle and height adjustment

"OUT OF  $\pm 3^\circ$ " AUDIBLE AND VISUAL WARNING

IP54 WATERPROOF



folding legs for angle and height adjustment

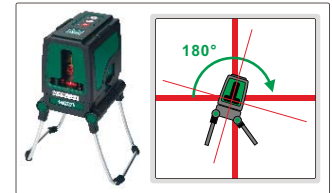

**SPECIFICATION**

|                       |   |
|-----------------------|---|
| List Price (₹)        | 6693  |
| Promotion Price (₹)   | 5737  |
| Laser line width      | 2 $\pm$ 0.5mm/5m  |
| Laser type            | 630~660nm, class II, <1mW                                 |
| Beam angle            | 120 $\pm$ 0.5°  |
| Self-leveling range   | $\pm 3^\circ$   |
| Working distance      | indoor: 30m, outdoor: 50m with detector (optional)        |
| Accuracy              | 0.2mm/m   |
| Operation temperature | -10~40°C  |
| Power supply          | 3 $\times$ AA batteries, for 3 hours continuous operation |
| Dimension             | 100 $\times$ 82 $\times$ 104mm                            |
| Weight                | 620g  |

application examples



**OPTIONAL ACCESSORY**

|                  |               |
|------------------|---------------|
| Outdoor detector | 4917-DETECTOR |
|------------------|---------------|

**STANDARD DELIVERY**

|                             |       |
|-----------------------------|-------|
| Main unit                   | 1 pc  |
| 1/4" to 5/8" tripod adaptor | 1 pc  |
| Battery (AA)                | 3 pcs |

**DIGITAL LEVEL AND PROTRACTOR**

- ▶ Aluminum frame
- ▶ Magnetic bottom with V-groove for shafts
- ▶ Zero setting can be made on any plain surfaces
- ▶ Buttons: ON/OFF, ZERO, HOLD (keep the reading)
- ▶ CR2032 battery, automatic power off

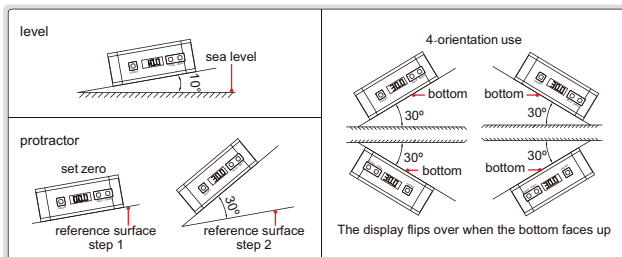

2173-360

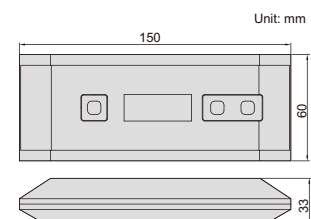

| Code     | Range                   | Resolution         | Accuracy   | List Price (₹) | Promotion Price (₹) |
|----------|-------------------------|--------------------|--|----------------|---------------------|
| 2173-360 | 0-360° (90° $\times$ 4) | 0.1° (=1.745 mm/m) | at 0° and 90°: $\pm 0.1^\circ$ , others: $\pm 0.2^\circ$ | 6015           | 3779                |

## DIGITAL LEVEL AND PROTRACTOR

- ▶ Aluminum frame, magnetic bottom
- ▶ The display flips over when the bottom faces up
- ▶ The backlight is on automatically when in use, and automatically off in 15 minutes after use
- ▶ The sea level is permanently set inside the chip, zero setting is not needed when battery is replaced
- ▶ Buttons: ON/OFF, ZERO, absolute and incremental measurement
- ▶ One AAA battery, automatic power off in 5 minutes



2170-1

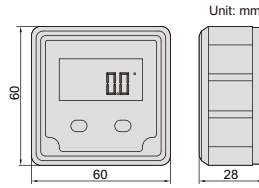

- ABSOLUTE LEVEL
- MAGNETIC BOTTOM
- BACKLIGHT

DISPLAY FLIPS OVER WHEN THE BOTTOM FACES UP

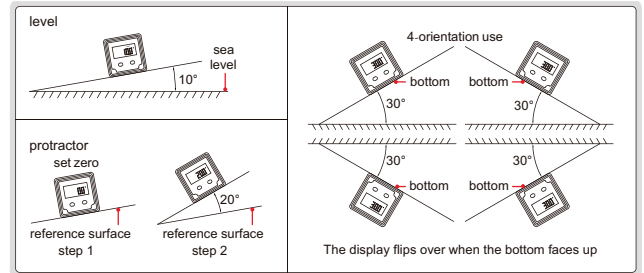

| Code   | Range | Resolution            | Accuracy                               | List Price (₹) | Promotion Price (₹) |
|--------|-------|-----------------------|--|----------------|---------------------|
| 2170-1 | 4x90° | 0.1°<br>(=1.745 mm/m) | at 0° and 90°: ±0.1°,<br>others: ±0.2° | 2692           | 1828                |

## DIGITAL LEVEL AND PROTRACTOR

- ▶ Ip54 dust/waterproof
- ▶ Aluminum frame
- ▶ Magnetic bottom with V-groove for shafts
- ▶ The sea level is permanently set inside the chip, zero setting is not needed when batteries are replaced
- ▶ Buttons: ON/OFF, absolute and incremental measurement, keep the reading, buzzer alarm, unit (mm/m, %, in/ft), backlight
- ▶ Two AAA batteries, automatic power off



2179-360

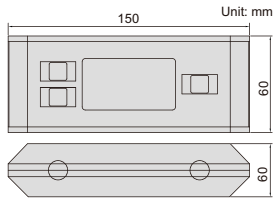

- IP54 WATERPROOF
- ABSOLUTE LEVEL
- BACKLIGHT
- BUZZER ALARM AT 0° AND 90°

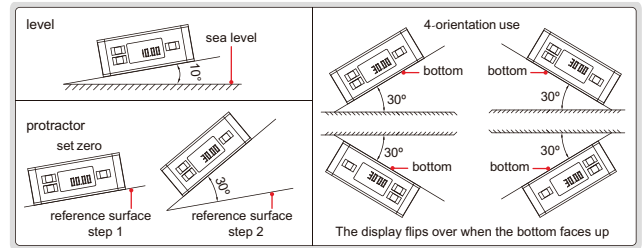

| Code     | Range             | Resolution             | Accuracy                               | List Price (₹) | Promotion Price (₹) |
|----------|-------------------|------------------------|--|----------------|---------------------|
| 2179-360 | 0-360°<br>(90°x4) | 0.05°<br>(=0.873 mm/m) | at 0° and 90°: ±0.1°,<br>others: ±0.2° | 6391           | 4159                |

## DIGITAL LEVEL



4910-600

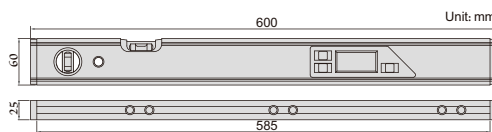

- ▶ With transverse and longitudinal vials
- ▶ Used as level and protractor
- ▶ Aluminum frame
- ▶ Magnetic bottom
- ▶ The sea level is permanently set inside the chip, zero setting is not needed when batteries are replaced
- ▶ Buttons: ON/OFF, absolute and incremental measurement, keep the reading, buzzer alarm, unit (mm/m, %, in/ft) conversion, backlight
- ▶ The display flips over when the bottom faces up
- ▶ Two AAA batteries, automatic power off

- BACKLIGHT
- ABSOLUTE LEVEL
- BUZZER ALARM AT 0° AND 90°

| Code     | Range             | Resolution            | Accuracy                               | List Price (₹) | Promotion Price (₹) |
|----------|-------------------|-----------------------|--|----------------|---------------------|
| 4910-600 | 0-360°<br>(90°x4) | 0.1°<br>(=1.745 mm/m) | at 0° and 90°: ±0.1°,<br>others: ±0.2° | 5376           | 3898                |

## ALUMINUM LEVELS

- ▶ Shockproof horizontal and vertical vials
- ▶ Magnetic base
- ▶ Shock absorbing rubber end caps
- ▶ Working temperature: -15°C~55°C



4914-600

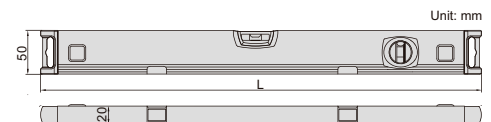

- VIALS MADE IN ISRAEL LIFETIME WARRANTY
- MAGNETIC BASE

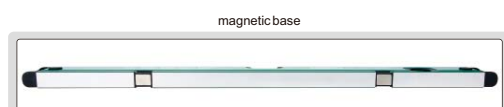

| Code      | Size (L) | Accuracy | List Price (₹) | Promotion Price (₹) |
|-----------|----------|----------|----------------|---------------------|
| 4914-300  | 300mm    | 0.5mm/m  | 851            | 744                 |
| 4914-600  | 600mm    | 0.5mm/m  | 1096           | 987                 |
| 4914-1000 | 1000mm   | 0.5mm/m  | 1568           | 1412                |

CAST ALUMINUM LEVEL

- ▶ Shockproof horizontal and vertical vials
- ▶ Magnetic base
- ▶ Working temperature: -15°C~55°C
- ▶ Cast aluminum body



4913-250

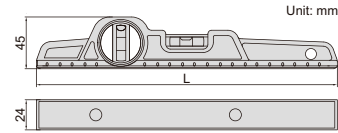

magnetic base



MAGNETIC BASE



VIALS MADE IN ISRAEL LIFETIME WARRANTY

| Code     | Size (L) | Accuracy | List Price (₹) | Promotion Price (₹) |
|----------|----------|----------|----------------|---------------------|
| 4913-250 | 250mm    | 0.5mm/m  | 774            | 697                 |

PORTABLE LEVEL

- ▶ Shockproof vials
- ▶ Magnetic base
- ▶ Shock absorbing rubber end caps
- ▶ Working temperature: -15°C~55°C

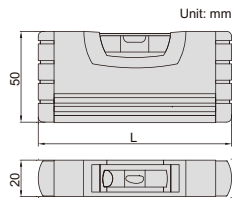

packaging



magnetic base



VIALS MADE IN ISRAEL LIFETIME WARRANTY

MAGNETIC BASE



4912-100

| Code     | Size (L) | Accuracy | List Price (₹) | Promotion Price (₹) |
|----------|----------|----------|----------------|---------------------|
| 4912-100 | 100mm    | 0.5mm/m  | 455            | 409                 |

PORTABLE LEEB HARDNESS TESTER  
CODE ISH-PHB

- ▶ Based on Leeb (HLD), converted to Vickers (HV), Brinell (HB), Rockwell (HRC and HRB), Shore (HS) and tensile strength (MPa)
- ▶ Memory of 99 measurement values for browsing
- ▶ Set measurement times (1~9) to have average value
- ▶ Connected with printer via bluetooth
- ▶ Automatic power off
- ▶ According to ASTM A 956



INSPECTION CERTIFICATE



hardness test block D (included)



small support ring (included)



wireless printer (optional)

SPECIFICATION

|                      |   |
|----------------------|---|
| List Price (₹)       | 50703   |
| Promotion Price (₹)  | 33219   |
| Min. reading         | 1HLD, 1HV, 1HB, 0.1HRC, 0.1HRB, 1HS, 1MPa   |
| Accuracy             | ±6HLD (when HLD=800)  |
| Display              | Leeb (HLD), converted hardness, material, impact direction, test times, average value, date |
| Output               | bluetooth   |
| Applicable workpiece | 5kg   |
|                      | 2kg (on solid support)  |
|                      | 0.1kg (coupled on plate)  |
|                      | minimum thickness: 5mm  |
|                      | minimum radius of curved surface: 30mm  |
|                      | maximum roughness (Ra): 1.6µm   |
| Power supply         | 3×AAA batteries   |
| Dimension            | 150×84×28mm   |
| Weight               | 200g  |

STANDARD DELIVERY

|                       |      |
|-----------------------|------|
| Main unit             | 1 pc |
| Impact device D       | 1 pc |
| Hardness test block D | 1 pc |
| Small support ring    | 1 pc |
| Cleaning brush        | 1 pc |

OPTIONAL ACCESSORY

|                       |                |
|-----------------------|----------------|
| Wireless printer      | ISH-DS-PRINTER |
| Couplant              | ISH-COULPLANT  |
| Support rings         | see details    |
| Hardness test block D | ISH-BHLD       |

## PORTABLE LEEB HARDNESS TESTER (BASIC MODEL) CODE ISHL-P200

- ▶ Supplied with impact device D and built-in printer
- ▶ Based on Leeb (HLD), converted to Vickers (HV), Brinell (HB), Rockwell (HRC and HRB), Shore (HS) and tensile strength (MPa)
- ▶ Set test times (1~32) to have average value
- ▶ Memory of 100 test values for browsing, print and output
- ▶ Low and high limits with judgement
- ▶ Automatic power off

### SPECIFICATION

|                      |  |
|----------------------|--|
| List Price (₹)       | 48544  |
| Promotion Price (₹)  | 42087  |
| Min. reading         | 1HLD, 1HV, 1HB, 0.1HRC, 0.1HRB, 1HS, 1MPa  |
| Accuracy             | ±8HLD (when HLD=760±30)  |
| Display              | Leeb, conversion hardness, material, impact direction, test times, average value, time |
| Applicable workpiece | 5kg  |
|                      | 2kg (on solid support)   |
|                      | 0.1kg (coupled on plate)   |
|                      | minimum thickness: 5mm   |
|                      | minimum radius of curved surface: 30mm   |
|                      | maximum roughness (Ra): 1.6µm  |
| Power supply         | built-in rechargeable battery  |
| Dimension            | 198×82×30mm  |
| Weight               | 320g   |

WITH BUILT-IN  
PRINTER

DATA  
OUTPUT



### STANDARD DELIVERY

|                        |      |
|------------------------|------|
| Main unit with printer | 1 pc |
| Impact device D        | 1 pc |
| Hardness test block D  | 1 pc |
| Printer paper          | 1 pc |
| Small support ring     | 1 pc |
| Cleaning brush         | 1 pc |
| USB cable and software | 1 pc |
| AC/DC adapter          | 1 pc |

hardness test block D (included)

small support ring (included)

### OPTIONAL ACCESSORY

|                       |                 |
|-----------------------|-----------------|
| Couplant              | ISH-COUPPLANT   |
| Hardness test block D | ISHL-P100-BLOCK |
| Printer paper         | ISHL-P200-PAPER |
| Support rings         | see details     |



## PORTABLE HARDNESS TESTER (BASIC MODEL) CODE ISHL-P100

### SPECIFICATION

|                      |  |
|----------------------|--|
| List Price (₹)       | 41121  |
| Promotion Price (₹)  | 24620  |
| Min. reading         | 1HLD, 1HV, 1HB, 0.1HRC, 0.1HRB, 1HS, 1MPa  |
| Accuracy             | ±8HLD (when HLD=760±30)  |
| Display              | Leeb, conversion hardness, material, impact direction, test times, average value, time |
| Applicable workpiece | 5kg  |
|                      | 2kg (on solid support)   |
|                      | 0.1kg (coupled on plate)   |
|                      | minimum thickness: 5mm   |
|                      | minimum radius of curved surface: 30mm   |
|                      | maximum roughness (Ra): 1.6µm  |
| Power supply         | 3×AAA batteries  |
| Dimension            | 155×72×27mm  |
| Weight               | 280g   |

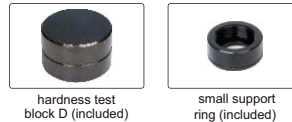

### STANDARD DELIVERY

|                       |      |
|-----------------------|------|
| Main unit             | 1 pc |
| Impact device D       | 1 pc |
| Hardness test block D | 1 pc |
| Small support ring    | 1 pc |
| Cleaning brush        | 1 pc |

### OPTIONAL ACCESSORY

|                       |                 |
|-----------------------|-----------------|
| Couplant              | ISH-COUPPLANT   |
| Hardness test block D | ISHL-P100-BLOCK |
| Support rings         | see details     |



- ▶ Supplied with impact device D
- ▶ Based on Leeb (HLD), converted to Vickers (HV), Brinell (HB), Rockwell (HRC and HRB), Shore (HS) and tensile strength (MPa)
- ▶ Set test times (1~32) to have average value
- ▶ Memory of 100 test values for browsing
- ▶ Automatic power off

## SHORE DUROMETERS

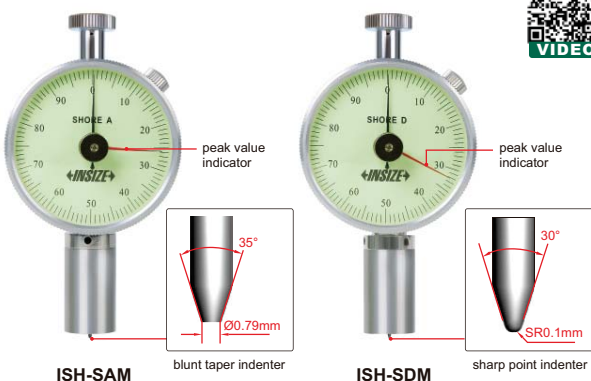

- ▶ According to ISO868, ISO7619, ASTM D 2240
- ▶ With peak value indicator
- ▶ Optional accessory: test stand ISH-STAC and ISH-STD

### SPECIFICATION

| Code                | ISH-SAM                              | ISH-SDM                                    |
|---------------------|--------------------------------------|--|
| List Price (₹)      | 8330                                 | 14620                                      |
| Promotion Price (₹) | 6137                                 | 10459                                      |
| Scale               | Shore A                              | Shore D                                    |
| Application         | natural rubber, soft elastomer, etc. | hard rubber, plastic, hard elastomer, etc. |
| Measuring range*    | 10~90HA                              | 20~90HD                                    |
| Graduation          | 1HA                                  | 1HD  |
| Indenter protrusion | 2.5mm                                |  |
| Dimension           | 115x60x25mm                          |  |
| Weight              | 160g                                 |  |

\* Use ISH-SDM when measuring result is higher than 90HA  
Use ISH-SAM when measuring result is lower than 20HD

FORCE GAGES

TWO SCALES  
N & KGF

- ▶ Push and pull test
- ▶ Peak (max.) or tracking mode



ISF-F500

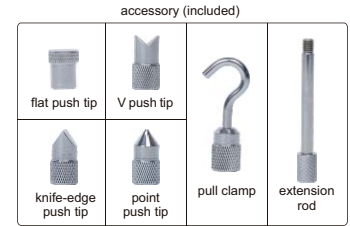

SPECIFICATION

| Code                | ISF-F10                | ISF-F20 | ISF-F30 | ISF-F50 | ISF-F100 | ISF-F200 | ISF-F300 | ISF-F500 |     |
|---------------------|------------------------|---------|---------|---------|----------|----------|----------|----------|-----|
| List Price (₹)      | 10375                  | 10375   | 10375   | 9057    | 9057     | 9057     | 9057     | 9057     |     |
| Promotion Price (₹) | 7409                   | 7409    | 7409    | 7409    | 7409     | 7409     | 7409     | 7409     |     |
| Capacity            | N                      | 10      | 20      | 30      | 50       | 100      | 200      | 300      | 500 |
|                     | kgf                    | 1       | 2       | 3       | 5        | 10       | 20       | 30       | 50  |
| Graduation          | N                      | 0.05    | 0.1     | 0.2     | 0.25     | 0.5      | 1        | 2        | 2.5 |
| Accuracy            | ±1% (of load capacity) |         |         |         |          |          |          |          |     |

STANDARD DELIVERY

|               |   |
|---------------|---|
| Main unit     | 1 pc                                    |
| Push tip      | 4 pcs (flat, V type, knife-edge, point) |
| Pull clamp    | 1 pc                                    |
| Extension rod | 1 pc                                    |

OPTIONAL ACCESSORY

|            |           |
|------------|-----------|
| Test stand | ISF-MT500 |
|------------|-----------|

TORQUE WRENCHES

ATTENTION: CLOCKWISE  
OPERATION ONLY



- ▶ According to DIN ISO 6789, ASME B107.300
- ▶ All-metal construction, sturdy and durable



IST-9WM335

SPECIFICATION

| Code                | IST-9WM20                    | IST-9WM30                    | IST-9WM60 | IST-9WM100 | IST-9WM125 | IST-9WM200 | IST-9WM335 | IST-9WM500 |
|---------------------|------------------------------|------------------------------|-----------|------------|------------|------------|------------|------------|
| List Price (₹)      | 6810                         | 6356                         | 6496      | 6735       | 7216       | 7234       | 7741       | 40459      |
| Promotion Price (₹) | 5954                         | 5557                         | 5679      | 5888       | 6309       | 6325       | 6768       | 35373      |
| Range (clockwise)   | 4~20N.m                      | 6~30N.m                      | 10~60N.m  | 20~100N.m  | 25~125N.m  | 40~200N.m  | 65~335N.m  | 100~500N.m |
| Accuracy            | ±6% (<10N.m)<br>±4% (≥10N.m) | ±6% (<10N.m)<br>±4% (≥10N.m) | ±4%       | ±4%        | ±4%        | ±4%        | ±4%        | ±4%        |
| Graduation          | 0.1N.m                       | 0.2N.m                       | 0.5N.m    | 0.5N.m     | 0.5N.m     | 1N.m       | 1N.m       | 2.5N.m     |
| Square driver (D)   | 1/4"                         | 3/8"                         | 3/8"      | 1/2"       | 1/2"       | 1/2"       | 1/2"       | 3/4"       |
| Length              | 290mm                        | 318mm                        | 388mm     | 443mm      | 443mm      | 468mm      | 528mm      | 855mm      |
| Weight              | 680g                         | 820g                         | 960g      | 1040g      | 1040g      | 1160g      | 1300g      | 5000g      |

DIAL TORQUE WRENCHES

ACCURACY ±3%



- ▶ Clockwise and counter-clockwise operation
- ▶ According to DIN ISO 6789, ASME B107.300



IST-DW70

SPECIFICATION

| Code                | IST-DW3D5               | IST-DW9                | IST-DW18                 | IST-DW35               | IST-DW70                 | IST-DW140                | IST-DW240                | IST-DW350                |
|---------------------|-------------------------|------------------------|--------------------------|------------------------|--------------------------|--------------------------|--------------------------|--------------------------|
| List Price (₹)      | 10526                   | 10526                  | 10886                    | 10886                  | 12170                    | 13992                    | 13992                    | 13992                    |
| Promotion Price (₹) | 9521                    | 9521                   | 9845                     | 9845                   | 11006                    | 12654                    | 12654                    | 12654                    |
| Range               | 0.7~3.5N.m<br>6~30in.lb | 1.8~9N.m<br>15~75in.lb | 3.6~18N.m<br>30~150in.lb | 7~35N.m<br>60~300in.lb | 14~70N.m<br>120~600in.lb | 28~140N.m<br>20~100ft.lb | 48~240N.m<br>35~175ft.lb | 70~350N.m<br>50~250ft.lb |
| Accuracy            | ±3%                     | ±3%                    | ±3%                      | ±3%                    | ±3%                      | ±3%                      | ±3%                      | ±3%                      |
| Graduation          | 0.05N.m<br>0.5in.lb     | 0.1N.m<br>1in.lb       | 0.2N.m<br>2in.lb         | 0.5N.m<br>5in.lb       | 1N.m<br>10in.lb          | 2N.m<br>1ft.lb           | 3N.m<br>2.5ft.lb         | 2.5N.m<br>2.5ft.lb       |
| Square driver (D)   | 1/4"                    | 1/4"                   | 3/8"                     | 3/8"                   | 3/8"                     | 1/2"                     | 1/2"                     | 1/2"                     |
| Length              | 254mm                   | 254mm                  | 254mm                    | 254mm                  | 378mm                    | 546mm                    | 546mm                    | 546mm                    |
| Weight              | 480g                    | 480g                   | 480g                     | 480g                   | 820g                     | 1300g                    | 1300g                    | 1300g                    |

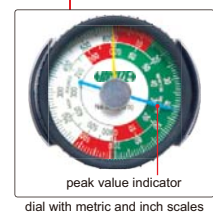

CODE NO. INDEX

| CODE...HSN...PAGE      | CODE...HSN...PAGE     | CODE.....HSN.....PAGE         |
|------------------------|-----------------------|-------------------------------|
| 11                     | 3240...90173010.... 4 | 7353...90173029..... 8        |
| 1106...90173010.... 1  | 3241...90173010.... 4 | <b>75</b>                     |
| 1108...90173010.... 1  | 3260...90173010.... 6 | 7511...90314900..... 23       |
| 1112...90173010.... 1  | <b>35</b>             | 7512...90314900..... 24       |
| 1120...90173010.... 3  | 3520...90173010.... 8 | 7513...90314900..... 24       |
| 1136...90173010.... 1  | <b>41</b>             | 7514...90314900..... 24       |
| 1141...90173029.... 3  | 4100...90173029...11  | 7515...90314900..... 24       |
| 1148...90173029.... 3  | 4166...90173023...11  | 7516...90314900..... 25       |
| 1149...90173010.... 3  | <b>42</b>             | 7517...90314900..... 25       |
| 1150...90318000.... 4  | 4206...90173029.... 9 | 7518...90314900..... 24       |
| 1154...90318000.... 5  | <b>46</b>             | <b>80</b>                     |
| 1156...90318000.... 5  | 4602...90173029...12  | 8001...84239010..... 33       |
| 1176...90173010.... 2  | <b>47</b>             | 8002...84239010..... 33       |
| 1196...90173010.... 1  | 4790...90173029...12  | <b>81</b>                     |
| <b>12</b>              | 4799...90173029...12  | 8101...84239010..... 34       |
| 1205...90173010.... 1  | <b>48</b>             | <b>89</b>                     |
| 1214...90173010.... 2  | 4801...90173029...13  | 8910...90249000..... 34       |
| 1240...90173029.... 3  | 4820...90173029...13  | <b>92</b>                     |
| 1250...90318000.... 5  | 4832...90173029...14  | 9221...90292010..... 31       |
| 1253...90318000.... 5  | 4833...90173029...13  | 9222...90292010..... 32       |
| <b>13</b>              | 4835...90173029...14  | 9241...90303100..... 32       |
| 1312...90173010.... 1  | 4836...90173029...13  | 9242...90303100..... 32       |
| <b>15</b>              | 4837...90173029...13  | 9243...90303100..... 33       |
| 1526...90173010.... 2  | 4838...90173029...14  | <b>93</b>                     |
| <b>21</b>              | 4839...90173029...14  | 9331...90318000..... 30       |
| 2103...90318000.... 9  | <b>49</b>             | 9341...90318000..... 31       |
| 2104...90318000.... 9  | 4903...90153010... 35 | 9351...90273090..... 31       |
| 2112...90318000.... 9  | 4910...90153010... 36 | <b>95</b>                     |
| 2141...90173029.... 4  | 4912...90153010... 37 | 9501...90318000..... 29       |
| 2170...90173029.... 36 | 4913...90153010... 37 | 9561...90318000..... 30       |
| 2172...90173029...12   | 4914...90153010... 36 | <b>ISD</b>                    |
| 2173...90173029...35   | 4917...90153010... 35 | ISD-V150...90318000..... 19   |
| 2176...90173029...11   | <b>53</b>             | ISD-V250...90318000..... 19   |
| 2179...90173029...36   | 5302...90112000... 22 | ISD-V300...90318000..... 19   |
| <b>22</b>              | 5303...90112000... 21 | <b>ISF</b>                    |
| 2222...90173010...10   | 5304...90112000... 21 | ISF-Fxxx...90318000..... 39   |
| 2275...90173029...12   | <b>61</b>             | <b>ISH</b>                    |
| 2276...90173029...15   | 6140...90179000.... 2 | ISH-PHB...90248091..... 37    |
| 2278...90173029...16   | 6144...90179000.... 2 | ISH-SAM...90248091..... 38    |
| <b>23</b>              | <b>62</b>             | ISH-SDM...90248091..... 38    |
| 2301...90318000.... 9  | 6200...85051900...10  | <b>ISHL</b>                   |
| 2302...90318000.... 9  | 6201...85051900...10  | ISHL-P100...90248091..... 34  |
| 2313...90318000.... 9  | 6202...85051900...10  | ISHL-P200...90248091..... 38  |
| 2322...90173029.... 8  | 6208...85051900...10  | <b>ISM</b>                    |
| 2341...90318000.... 4  | 6210...85051900...10  | ISM-DL301...90112000..... 20  |
| 2342...90173010.... 4  | 6211...85051900...10  | ISM-PM200SA...90112000... 22  |
| 2364...90173029...11   | 6291...90319000...10  | ISM-ZS30...90112000..... 23   |
| 2372...90173029...12   | <b>63</b>             | ISM-ZS50...90112000..... 23   |
| 2380...90318000...10   | 6301...90173029.... 7 | <b>ISP</b>                    |
| 2381...90318000...10   | 6381...90318000.... 7 | ISP-Z3015...90318000..... 18  |
| 2385...90318000...16   | <b>65</b>             | <b>ISQ</b>                    |
| 2397...90318000...17   | 6562...90318000...17  | ISQ-RM30...90292030..... 34   |
| <b>28</b>              | 6566...90318000...17  | <b>ISR</b>                    |
| 2824...90173029.... 8  | <b>71</b>             | ISR-C002...90318000..... 28   |
| 2852...90173029.... 8  | 7110...90172010...15  | ISR-C003...90318000..... 28   |
| 2862...90173029...11   | 7123...90172010...15  | ISR-C100...90318000..... 26   |
| 2871...90173029...11   | 7144...90178090...16  | ISR-C300...90318000..... 27   |
| <b>31</b>              | 7145...90178090...16  | <b>IST</b>                    |
| 3101...90173010.... 6  | 7160...90173010... 25 | IST-9WMxxx...82041220... 39   |
| 3108...90173010.... 6  | 7161...90173010... 25 | IST-DWxxx...82041220... 39    |
| 3109...90173010.... 5  | 7162...90173010... 25 | <b>ISU</b>                    |
| <b>32</b>              | 7163...90173010... 26 | ISU-100D...90318000..... 30   |
| 3203...90173010.... 6  | <b>72</b>             | <b>ISV</b>                    |
| 3206...90173010.... 7  | 7260...90173029...15  | ISV-2000DS...90112000..... 29 |
| 3210...90173010.... 6  | 7261...90173010...15  |                               |
| 3220...90173010.... 7  | 7262...90173010...15  |                               |
| 3222...90173010.... 8  | <b>73</b>             |                               |
| 3227...90173010.... 7  | 7315...85444299...17  |                               |

HSN codes subject to change.

SALES

INSIZE is our standard quality and made in Asia – Korea, China, Taiwan etc.



INSIZE PLUS is our premium quality and mainly made in Germany, UK and Italy.

- Some products marked with 'Basic model' are only for basic use.
- Quality Warranty** – 12 months, against manufacturing defect. Repair or replacement will be at the discretion of the manufacturer.
- For verification of genuineness refer bar code sticker on the box.
- Manufacturer inspection certificates traceable to DKD Germany or NIST USA are provided with instruments marked in asterisk.

SERVICE

- Mobile App: scan QR code to download mobile App to view online stock and price on mobile.
- Refer to Website <http://www.insizeindia.in> for Indiamart promotion.

SPARES

- Many spares will be available ex-stock.

REPAIRS

- Online help will be provided to repair the instrument yourself. Or you can either return the instrument to us at Ahmedabad or to the dealer along with the invoice on paid basis for faster process. Not necessary to approach our dealer for repairs.

CALIBRATION

- Ask for NABL calibration from our Dealers at extra but economical rates.

DEMO & TECHNICAL ASSISTANCE

- Demo will be provided at our showroom in Ahmedabad and at exhibitions in your city. Refer our website <http://www.insize.in/exhibition.php>, to know about our participation in your city.
- We provide "Custom Made Calipers". Please provide drawings.



Download mobile App for ONLINE STOCK and PRICE from: <http://insize.in/insizeapp/apk/insize.apk>



Watch operation videos at <http://www.insize.com/support.php>



INSIZE (INDIA)

B - 14, GF, Jayraj Complex, Opp. Bank of Baroda Soni Ni Chawl, Odhav, Ahmedabad-382415 Gujarat, India.

| Matter              | E-mail ID / Link / Web Address               |              |                        |
|---------------------|--|--------------|------------------------|
| Quote               | sales-in@insize.com, cc: india@insize.com    |              |                        |
| Online Stock        | insize.in/login.php, then-user ID & password |              |                        |
| Website             | www.insize.in                                |              |                        |
|                     | Mobile                                       | Telephone    | E-mail ID              |
| OA, Invoice, A/c    | 7819819938                                   | 079-29709508 | india@insize.com       |
| Sales               | 7819819939                                   | 9624899956   | ahmedabad@insize.com   |
| Technical           | 7819819939                                   | 079-22890202 | ahmedabad@insize.com   |
| Repairing           | 9662519942                                   | 079-22890202 |                        |
| Dispatch            | 7874411947                                   | 079-29709508 | india@insize.com       |
| Calibration         | 9860779643                                   | 9624899973   | insizecall@outlook.com |
| Policy / Dealership | 9327004639 - Mrs. Jalpa Mehta                |              | shrikesh@insize.com    |

Distributed by:

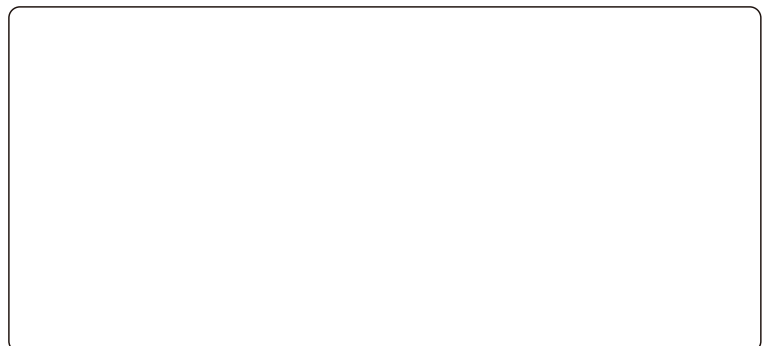

| Download           | Link  |
|--------------------|---|
| Catalog            | <a href="http://www.insize.in/catalogue.php">http://www.insize.in/catalogue.php</a>                 |
| Promotion          | <a href="http://www.insize.com/products/pdf/pro.php">http://www.insize.com/products/pdf/pro.php</a> |
| Price List         | <a href="http://www.insize.in/catalogue.php">http://www.insize.in/catalogue.php</a>                 |
| Application Index  | <a href="http://www.insize.in/products/app.php">http://www.insize.in/products/app.php</a>           |
| Operation Manual   | <a href="http://www.insize.com/login1.php">http://www.insize.com/login1.php</a>                     |
| Operation Video    | <a href="http://www.insize.in/support.php">http://www.insize.in/support.php</a>                     |
| Spares             | <a href="http://www.insize.in/spares.php">http://www.insize.in/spares.php</a>                       |
| Exhibition List    | <a href="http://www.insize.in/exhibition.php">http://www.insize.in/exhibition.php</a>               |
| Verify Genuineness | <a href="http://www.insize.com/verify.php">http://www.insize.com/verify.php</a>                     |